

PHILIPS

Data handbook



Electronic
components
and materials

Components and materials

Part 12 November 1979

Variable resistors

Test switches

COMPONENTS AND MATERIALS

PART 12 - NOVEMBER 1979

VARIABLE RESISTORS AND TEST SWITCHES

VARIABLE RESISTORS

TEST SWITCHES

CONTENTS



DATA HANDBOOK SYSTEM

Our Data Handbook System is a comprehensive source of information on electronic components, sub-assemblies and materials; it is made up of three series of handbooks each comprising several parts.

ELECTRON TUBES	BLUE
SEMICONDUCTORS AND INTEGRATED CIRCUITS	RED
COMPONENTS AND MATERIALS	GREEN

The several parts contain all pertinent data available at the time of publication, and each is revised and reissued periodically.

Where ratings or specifications differ from those published in the preceding edition they are pointed out by arrows. Where application information is given it is advisory and does not form part of the product specification.

If you need confirmation that the published data about any of our products are the latest available, please contact our representative. He is at your service and will be glad to answer your inquiries.

This information is furnished for guidance, and with no guarantee as to its accuracy or completeness; its publication conveys no licence under any patent or other right, nor does the publisher assume liability for any consequence of its use; specifications and availability of goods mentioned in it are subject to change without notice; it is not to be reproduced in any way, in whole or in part without the written consent of the publisher.

ELECTRON TUBES (BLUE SERIES)

Part 1a	December 1975	ET1a 12-75	Transmitting tubes for communication, tubes for r.f. heating Types PE05/25 to TBW15/25
Part 1b	August 1977	ET1b 08-77	Transmitting tubes for communication, tubes for r.f. heating, amplifier circuit assemblies
Part 2a	November 1977	ET2a 11-77	Microwave tubes Communication magnetrons, magnetrons for microwave heating, klystrons, travelling-wave tubes, diodes, triodes T-R switches
Part 2b	May 1978	ET2b 05-78	Microwave semiconductors and components Gunn, Impatt and noise diodes, mixer and detector diodes, backward diodes, varactor diodes, Gunn oscillators, sub-assemblies, circulators and isolators
Part 3	January 1975	ET3 01-75	Special Quality tubes, miscellaneous devices
Part 4	March 1975	ET4 03-75	Receiving tubes
Part 5a	October 1979	ET5a 10-79	Cathode-ray tubes Instrument tubes, monitor and display tubes, C.R. tubes for special applications
Part 5b	December 1978	ET5b 12-78	Camera tubes and accessories, image intensifiers
Part 6	January 1977	ET6 01-77	Products for nuclear technology Channel electron multipliers, neutron tubes, Geiger-Müller tubes
Part 7a	March 1977	ET7a 03-77	Gas-filled tubes Thyratrons, industrial rectifying tubes, ignitrons, high-voltage rectifying tubes
Part 7b	May 1979	ET7b 05-79	Gas-filled tubes Segment indicator tubes, indicator tubes, switching diodes, dry reed contact units
Part 8	July 1979	ET8 07-79	Picture tubes and components Colour TV picture tubes, black and white TV picture tubes, monitor tubes, components for colour television, components for black and white television.
Part 9	March 1978	ET9 03-78	Photomultiplier tubes; phototubes

SEMICONDUCTORS AND INTEGRATED CIRCUITS (RED SERIES)

Part 1a	August 1978	SC1a 08-78	Rectifier diodes, thyristors, triacs Rectifier diodes, voltage regulator diodes (> 1,5 W), transient suppressor diodes, rectifier stacks, thyristors, triacs
Part 1b	May 1977	SC1b 05-77	Diodes Small signal germanium diodes, small signal silicon diodes, special diodes, voltage regulator diodes (< 1,5 W), voltage reference diodes, tuner diodes
Part 2	November 1977	SC2 11-77	Low-frequency and dual transistors*
Part 2	June 1979	SC2 06-79	Low-frequency power transistors
Part 3	January 1978	SC3 01-78	High-frequency, switching and field-effect transistors
Part 4a	December 1978	SC4a 12-78	Transmitting transistors and modules
Part 4b	September 1978	SC4b 09-78	Devices for optoelectronics Photosensitive diodes and transistors, light emitting diodes, photocouplers, infrared sensitive devices, photoconductive devices
Part 4c	July 1978	SC4c 07-78	Discrete semiconductors for hybrid thick and thin-film circuits
Part 5a	November 1978	SC5a 11-76	Professional analogue integrated circuits
Part 5b	March 1977	SC5b 03-77	Consumer integrated circuits Radio-audio, television
Part 6	October 1977	SC6 10-77	Digital integrated circuits LOCMOS HE4000B family
Part 6b	August 1979	SC6b 08-79	ICs for digital systems in radio and television receivers
Signetics integrated circuits	1978		Bipolar and MOS memories Bipolar and MOS microprocessors Analogue circuits Logic - TTL

* Low-frequency general purpose transistors will be transferred to SC3 later in 1979. The old book SC2 11-77 should be kept until then.

COMPONENTS AND MATERIALS (GREEN SERIES)

Part 1	July 1979	CM1 07-79	Assemblies for industrial use PLC modules, high noise immunity logic FZ/30-series, NORbits 60-series, 61-series, 90-series, input devices, hybrid integrated circuits, peripheral devices
Part 2a	October 1977	CM2a 10-77	Resistors Fixed resistors, variable resistors, voltage dependent resistors (VDR), light dependent resistors (LDR), negative temperature coefficient thermistors (NTC), positive temperature coefficient thermistors (PTC), test switches
Part 2b	February 1978	CM2b 02-78	Capacitors Electrolytic and solid capacitors, film capacitors, ceramic capacitors, variable capacitors
Part 3a	September 1978	CM3a 09-78	FM tuners, television tuners, surface acoustic wave filters
Part 3b	October 1978	CM3b 10-78	Loudspeakers
Part 4a	November 1978	CM4a 11-78	Soft ferrites Ferrites for radio, audio and television, beads and chokes, Ferroxcube potcores and square cores, Ferroxcube transformer cores
Part 4b	February 1979	CM4b 02-79	Piezoelectric ceramics, permanent magnet materials
Part 6	April 1977	CM6 04-77	Electric motors and accessories Small synchronous motors, stepper motors, miniature direct current motors
Part 7	September 1971	CM7 09-71	Circuit blocks Circuit blocks 100 kHz-series, circuit blocks 1-series, circuit blocks 10-series, circuit blocks for ferrite core memory drive
Part 7a	January 1979	CM7a 01-79	Assemblies Circuit blocks 40-series and CSA70 (L), counter modules 50-series, input/output devices
Part 8	June 1979	CM8 06-79	Variable mains transformers
Part 9	August 1979	CM9 08-79	Piezoelectric quartz devices Quartz crystal units, temperature compensated crystal oscillators
Part 10	April 1978	CM10 04-78	Connectors
Part 11	December 1979	CM11 12-79	Non-linear resistors
Part 12	November 1979	CM12 11-79	Variable resistors and test switches
Part 13	December 1979	CM13 12-79	Fixed resistors

VARIABLE RESISTORS



Wirewound potentiometers	3
Carbon potentiometers	43
Cermet potentiometers	169

Outlines

Dimensions in mm

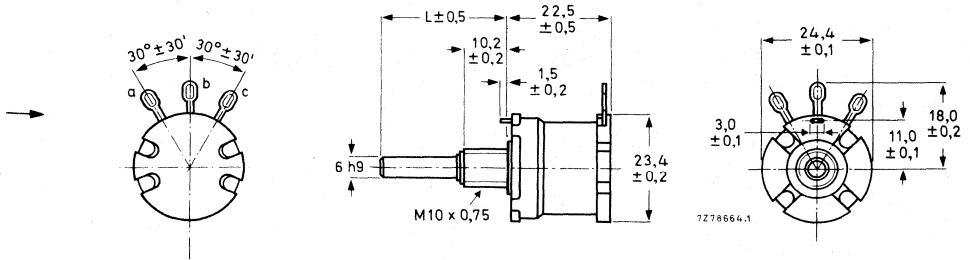

Fig. 1. Potentiometers 2322 003 with plain spindle. The spindle length L is 17, 20, 30 or 60 mm.

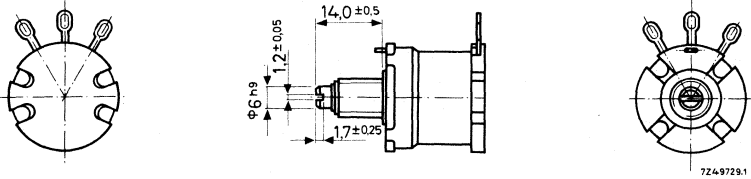

Fig. 2. Potentiometers 2322 003 with spindle with screwdriver slot. Dimensions are identical to those in Fig. 1. except as shown.

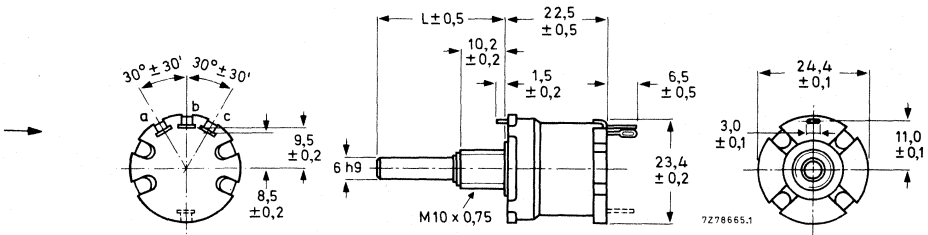

Fig. 3. Potentiometers 2322 010 with plain spindle. The spindle length L is 17, 20, 30 or 60 mm.

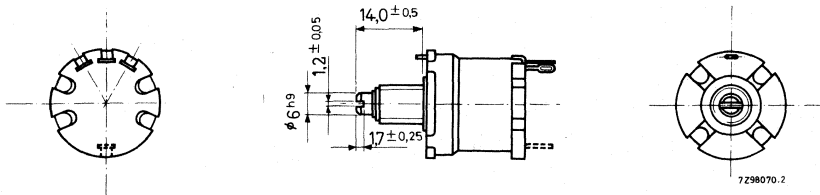

Fig. 4. Potentiometers 2322 010 with spindle with screwdriver slot. Dimensions are identical to those in Fig. 3. except as shown.

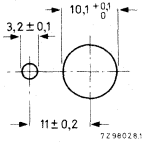

Fig. 5. Mounting holes

The potentiometers can be fixed to the chassis with the cadmium-plated mounting nut supplied (catalogue number 4322 047 00350). The minimum thickness of the chassis is 1 mm. The maximum torque for tightening is 3,5 Nm.

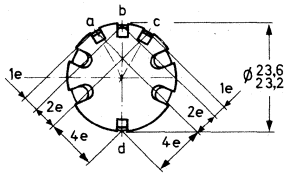
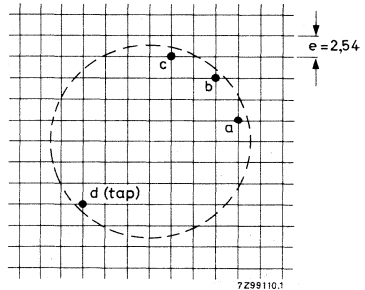

Fig. 6. Potentiometer with pins for printed-wiring; see also "CONSTRUCTION - Note".

Fig. 7. Hole pattern of the printed-wiring board.



TECHNICAL PERFORMANCE

Unless otherwise specified all values apply at an ambient temperature of $20 \pm 5 \text{ }^\circ\text{C}$, an atmospheric pressure of 930 to 1060 mbar and a relative humidity of 45 to 75%.

Nominal resistance values (R_n), measured between the tags a and c (see Figs. 1 and 3)
Tolerance on the nominal resistance

for $R_n \leq 47 \text{ } \Omega$
for $R_n > 47 \text{ } \Omega$

see Table

$\pm 10\%$
 $\pm 5\%$ and $\pm 10\%$
linear

Resistance law

Resistance at 50% of effective angle of rotation

$50\% \pm 2\%$ of R_{total}

Maximum permissible dissipation, the full

length of the resistance element being used

see Fig. 8

Temperature coefficient of the resistance

see Table

Insulation resistance

$> 1000 \text{ M}\Omega$

Test voltage between spindle and tags for

1 min

1000 V r. m. s.

Maximum working voltage between resistance element and case	500 V peak
Working temperature range	-10 to + 85 °C
Climatic category, IEC68	10/085/21
Number of windings	see Table
Effective angle of rotation	290 ± 10 °
Mechanical angle of rotation	300 ± 5 °
Operating torque	7, 5 to 20 mNm
End stop torque	≤ 800 mNm
Maximum axial spindle load	50 N
Life, for $R_n \leq 6,8 \text{ k}\Omega$	in excess of 25 000 cycles
for $R_n > 6,8 \text{ k}\Omega$	in excess of 10000 cycles

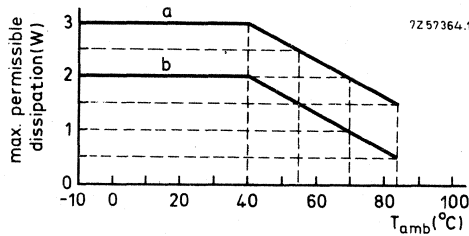
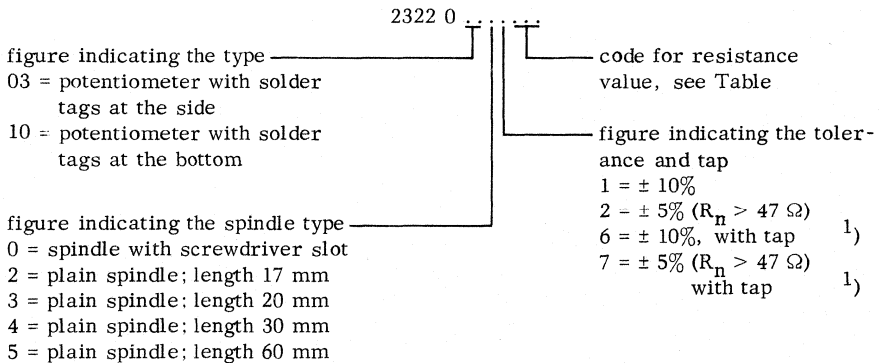

Fig. 8. Maximum permissible dissipation as a function of the ambient temperature.
 Curve a : for potentiometers mounted on a metal chassis of 100 mm x 100 mm x 1 mm.
 Curve b : for potentiometers mounted on an insulating panel.

COMPOSITION OF THE CATALOGUE NUMBER



¹⁾ Tap at 50% of the effective angle of rotation.

Table

resistance value (Ω)	temperature coefficient (ppm/degC)	number of windings $\pm 25\%$	code in catalogue number
2, 2	0 to +600	60	228
3, 3		55	338
4, 7		79	478
6, 8		71	688
10		105	109
15		102	159
22		150	229
33	-25 to +600	141	339
47		103	479
68	-25 to +25	96	689
100		142	101
150		128	151
220		188	221
330	-25 to +140	182	331
470		191	471
680	0 to +140	172	681
1 000		155	102
1 500		234	152
2 200		227	222
3 300		342	332
4 700		302	472
6 800		438	682
10 000	-20 to +140	413	103
15 000		497	153
22 000		448	223

WIRE-WOUND POTENTIOMETERS

QUICK REFERENCE DATA

Linear resistance law	
Resistance range	10 Ω to 50 000 Ω
Maximum permissible dissipation at 40 $^{\circ}\text{C}$	3 W
at 70 $^{\circ}\text{C}$	1,5 W

APPLICATION

In professional electric and electronic equipment where accurate and gradual resistance control and high stability are required.

Due to the large outer diameter, a very good resolution has been obtained compared with some other types.

CONSTRUCTION

The potentiometer consists of a single layer of resistance wire wound on a strip of resin-bonded paper and housed in a case of black synthetic resin, which is dust-proof sealed by a metal bottom.

The solder tags a and c (see Figs. 1 and 2) are connected to the ends of the resistance element.

A resilient slider, which is insulated from the steel spindle, slides over the flat top of the winding when the spindle is turned. The slider makes a sliding contact with the solder tag b by means of a slip ring. A stop prevents the slider from overrunning the resistance element.

Outlines

Dimensions in mm

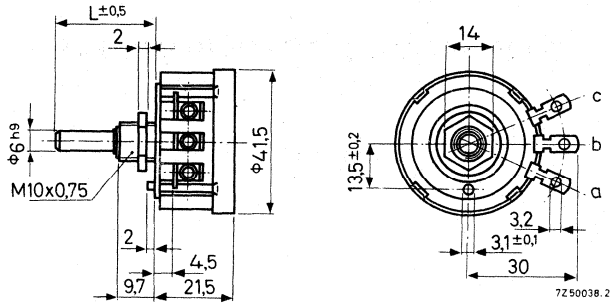

Fig. 1. Potentiometer with plain spindle. The spindle length L is 20, 25, 30, 35 or 80 mm.

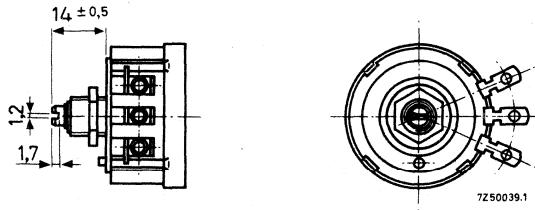
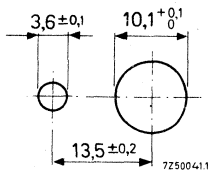

Fig. 2. Potentiometer with spindle with screwdriver slot. Dimensions are identical to those in Fig. 1 except as shown.



The potentiometers can be fixed to the chassis with the cadmium-plated mounting nut supplied (catalogue number 4322 047 00350). The maximum torque for tightening is 3,5 Nm.

Fig. 3. Mounting holes.

TECHNICAL PERFORMANCE

Unless otherwise specified all values apply at an ambient temperature of $20 \pm 5 \text{ }^\circ\text{C}$, an atmospheric pressure of 930 to 1060 mbar and a relative humidity of 45 to 75%.

Nominal resistance values (R_n), measured between the tags a and c (see Figs. 1 and 2)	see Table
Tolerance on the nominal resistance	
for $R_n \leq 75 \text{ } \Omega$	$\pm 10\%$
for $R_n > 75 \text{ } \Omega$	$\pm 5\%$ and $\pm 10\%$
Resistance law	linear
Resistance at 50% of effective angle of rotation	$50\% \pm 2\%$ of R_{total}
Maximum permissible dissipation, the full length of the resistance element being used, at $T_{amb} = 40 \text{ }^\circ\text{C}$	3 W
at $T_{amb} > 40 \text{ }^\circ\text{C}$	see Fig. 4
Temperature coefficient of the resistance	see Table
Insulation resistance	$> 100 \text{ M}\Omega$
Test voltage for 1 min	2000 V (r. m. s.)
Maximum working voltage between mounting bush and solder tags	1000 V (peak)
Ambient temperature range	-55 to $+100 \text{ }^\circ\text{C}$
Number of windings	see Table
Effective angle of rotation	$280 \pm 4^\circ$
Mechanical angle of rotation	$300 \pm 2^\circ$
Operating torque	10 to 30 mNm
End stop torque	$\leq 800 \text{ mNm}$
Life, for $R_n \leq 10 \text{ k}\Omega$	in excess of 25 000 cycles
for $R_n > 10 \text{ k}\Omega$	in excess of 10 000 cycles

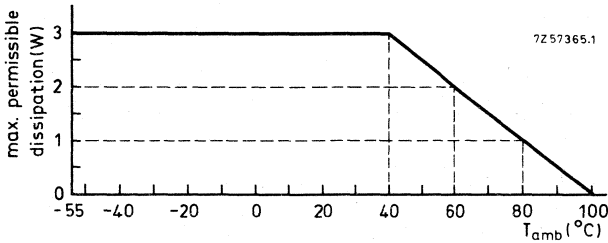

Fig. 4. Maximum permissible dissipation as a function of the ambient temperature.

COMPOSITION OF THE CATALOGUE NUMBER

2322 004

figure indicating the spindle type
 2 = spindle with screwdriver slot
 3 = plain spindle; length 20 mm
 4 = plain spindle; length 25 mm
 5 = plain spindle; length 30 mm
 6 = plain spindle; length 35 mm
 7 = plain spindle; length 80 mm

code for resistance value,
 see Table

figure indicating the tolerance
 1 = $\pm 10\%$
 2 = $\pm 5\%$ ($R_n > 75 \Omega$)

Table

resistance value (Ω)	temperature coefficient (ppm/deg C)	number of windings $\pm 25\%$	code in catalogue number
10	0 to +600	160	109
15		240	159
20		200	209
25		250	259
35		220	359
50		320	509
75		300	759
100	-25 to +25	200	101
150		190	151
200		260	201
250		320	251
350		280	351
500		410	501
750		380	751
1 000		510	102
1 500	0 to +140	360	152
2 000		480	202
2 500		380	252
3 500		530	352
5 000		750	502
7 500		710	752
10 000		600	103
15 000		560	153
20 000	710	203	
25 000	950	253	
35 000	-20 to +20	1050	353
50 000		1200	503

WIRE-WOUND PRESET POTENTIOMETERS

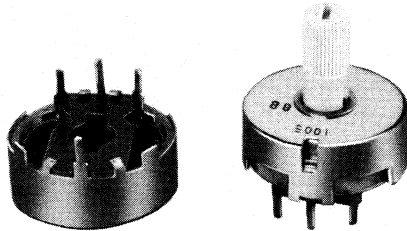

RZ26449-3

QUICK REFERENCE DATA

Linear resistance law	
Resistance range	2,2–4700 Ω
Maximum permissible dissipation	
at 40 °C	2 W
at 70 °C	1,5 W

APPLICATION

In a wide variety of electronic equipment, e.g. for presetting of the horizontal and vertical convergence in colour television receivers.

CONSTRUCTION

The potentiometers consist of a single layer of resistance wire housed in a metal case. The resistance element and its terminal pins (a and c, see Figs 1 and 2) are insulated from the case; the slider is connected to the case (pin b).

Four potentiometer types are available: with or without a tap (pin d) in the middle of the resistance element and with or without a plastic knob. The potentiometers are suitable for mounting on printed-wiring boards.

Note

The potentiometers are supplied with the slider at $50 \pm 5\%$ of the angle of rotation.

Outlines

Dimensions in mm

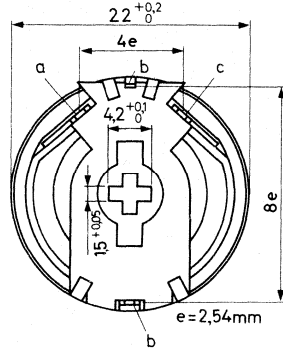
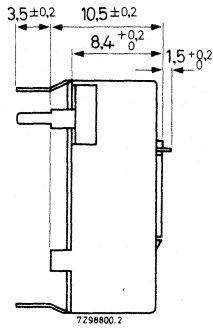

Fig.1 Non-tapped potentiometer without knob.

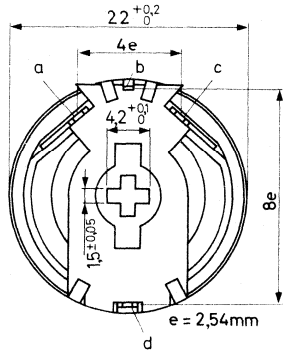
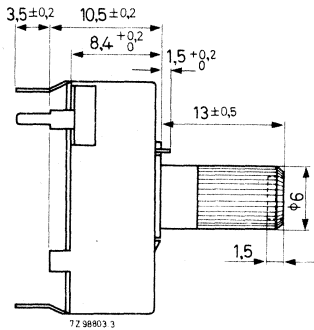

Fig.2 Tapped potentiometer with knob.

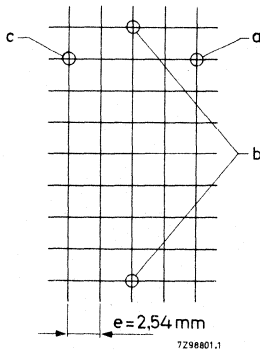

Fig.3 Mounting holes for non-tapped potentiometers.

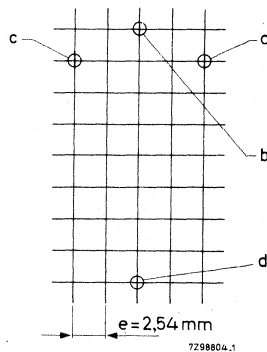

Fig.4 Mounting holes for tapped potentiometers.

TECHNICAL DATA

Nominal resistance value (R_n) between a and c	2,2 to 4700 Ω see Table 1
Resistance law	linear, see Figs.5 and 6
Tolerance on R_n	$\pm 10\%$
Resistance at beginning and end	$\leq 5\%$ of R_{total}
Resistance at 50% of effective angle of rotation	$50 \pm 2\%$ of R_{total}
Contact resistance between resistance element and slider	≤ 500 m Ω
Change of contact resistance between resistance element and slider	≤ 300 m Ω
Temperature coefficient	see Table 1
Maximum dissipation between a and c, potentiometer mounted on printed-wiring board (Fig.7)	
at $T_{amb} = 40$ °C	2 W
at $T_{amb} = 70$ °C	1,5 W
Ambient temperature range	-40 to +100 °C
Mechanical angle of rotation	$255 \pm 10^\circ$
Effective angle of rotation	$240 \pm 10^\circ$
Operating torque	10 to 40 mNm
Maximum end stop torque	150 mNm
Life	250 cycles

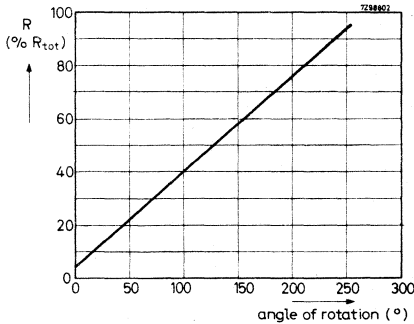

Fig.5 Resistance variation with the angle of rotation for non-tapped potentiometers.

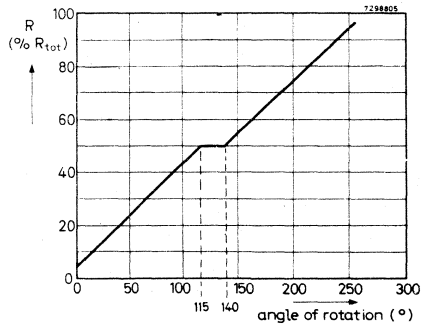

Fig.6 Resistance variation with the angle of rotation for tapped potentiometers.

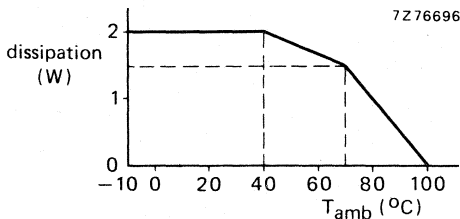

Fig.7 Dissipation as a function of the ambient temperature; potentiometer mounted on a printed-wiring board.



Table 1

resistance value Ω	temperature coefficient $10^{-6}/^{\circ}\text{C}$	number of turns	code in catalogue number
2,2	0 to +600	110	228
3,3		108	338
4,7		95	478
6,8		136	688
10		126	109
15		194	159
22	-25 to +25	113	229
33		134	339
47		120	479
68		172	689
100		160	101
120	0 to +140	138	121
150		178	151
180		207	181
220		165	221
330		155	331
470		222	471
680		200	681
1000		297	102
4700	330	472	
11 + 11	-25 to +25	113	229
50 + 50		160	101
150 + 150	0 to +140	150	301

COMPOSITION OF THE CATALOGUE NUMBER

2322 011

without tap or knob * = 02 ———— resistance code, see Table
 with tap, without knob * = 03
 without tap, with knob = 22
 with tap and knob = 23

→ MARKING

The potentiometers are marked at the front with nominal resistance value (according to IEC 62), production code (period and year) and code of manufacture (source code).

* Knobs are available under catalogue number 4322 048 20550.

WIRE-WOUND POTENTIOMETERS

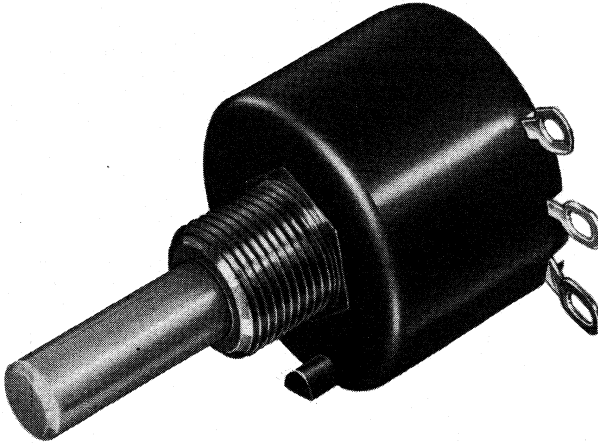

RZ 26297-1

Linear resistance law

Resistance range

2, 2-22 000 Ω

Maximum permissible dissipation at 70 °C

1 W

Potentiometers 2322 012.....

provided with a plastic spindle

Potentiometers 2322 013.....

provided with a steel spindle

APPLICATION

In professional electric and electronic equipment where accurate and gradual resistance regulation and high stability are required.

CONSTRUCTION

The potentiometer consists of a single layer of resistance wire wound on a strip of resin-bonded paper and housed in a dust-proof case of black plastic material. The resilient slider is affixed to the spindle; a stop prevents the slider from overrunning the resistance element, and the contact between resistance wire and slider is preserved over the entire angle of rotation, so as ensure minimum wear.

Outlines

Dimensions in mm

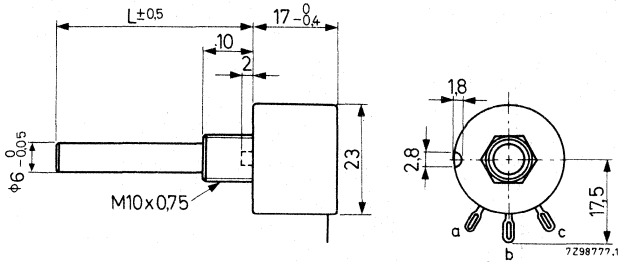

a. Potentiometer with a spindle suited for knob adjustment.
For spindle length L, see section "TYPES".

b. Spindle with screwdriver slot (spindle fully counter-clockwise).

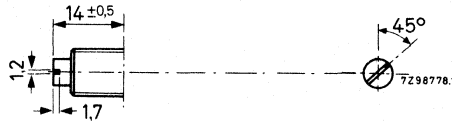

Fig. 1. Potentiometers 2322 012 and 2322 013 and their spindle types.
a and c are connected to the ends of the resistance wire; b is connected to the slider contact.

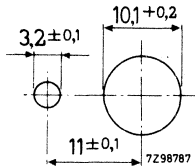

Fig. 2. Mounting holes.

The potentiometers can be fixed to the chassis with the cadmium-plated mounting nut supplied (catalogue number 4322 047 00350).

TECHNICAL PERFORMANCE

Nominal resistance values (R_N), measured between the tags a and c (see figure above)

see Table

Tolerance on the nominal resistance

for $R_N \leq 47 \Omega$
for $R_N > 47 \Omega$

$\pm 10\%$
 $\pm 5\%$ and $\pm 10\%$

Resistance law

linear

Resistance at 50% of effective angle of rotation

$50 \pm 2\%$ of R_{total}

Resistance at the beginning and end

for $R_N \leq 15 \Omega$
for $R_N \geq 22 \Omega$

$\leq 200 \text{ m}\Omega$
 $\leq 1\%$ of R_N

Contact resistance	see Fig. 3
Change of contact resistance	≤ 300 mΩ
Dissipation as a function of ambient temperature, potentiometers mounted on a metal chassis of 100 mm x 100 mm x 1 mm	see Fig. 4
Temperature coefficient of the resistance	see Table 1
Insulation resistance between bushing and contacts	> 1000 MΩ
Test voltage between bushing and contacts for 1 min	2000 V, 50 Hz
Maximum working voltage between bushing and contacts	1000 V _p
Working-temperature range	-10 to +100 °C
Climatic robustness	category 10/100/21 (I.E.C. 68)
Number of windings	see Table
Effective angle of rotation	245 ± 5°
Mechanical angle of rotation	270 ± 5°
Operating torque	0, 3-2 Ncm
End stop torque	≤ 80 Ncm
Maximum axial spindle load	100 N
Life, for R _n ≤ 3,3 kΩ	in excess of 25 000 cycles
for R _n > 3,3 kΩ	in excess of 10 000 cycles

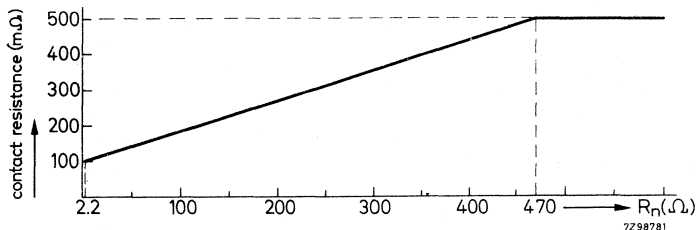

Fig. 3 Contact resistance as a function of the nominal resistance.

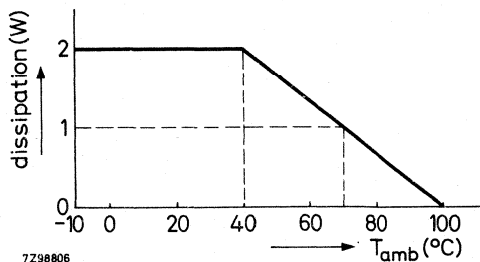

Fig. 4 Dissipation as a function of the ambient temperature.

TYPES

Composition of the catalog number 2322 01.

figure indicating the spindle material
2 = plastic
3 = steel

figure indicating the spindle type
0 = spindle suited for screwdriver adjustment;
length 14 mm (only plastic)

2 = length 17 mm
3 = length 25 mm
4 = length 50 mm
5 = length 60 mm
6 = length 20 mm
7 = length 30 mm

} spindle suited for knob adjustment

.....
code for resistance value, see Table
figure indicating the tolerance
1 = $\pm 10\%$
2 = $\pm 5\%$ ($R_n > 47 \Omega$)

Example: for a potentiometer with a nominal resistance value of 10Ω , tolerance $\pm 10\%$ for screwdriver adjustment, with a plastic spindle, the catalog number is 2322 012 01109.

Table

resistance value in Ω	temperature coefficient in $10^{-6}/\text{deg C}$	number of windings $\pm 25\%$	code in catalog number
2.2	0 to +600	47	228
3.3		70	338
4.7		63	478
6.8		90	688
10		85	109
15		127	159
22	-25 to +25	62	229
33		94	339
47		83	479
68		120	689
100		106	101
150		103	151
220	0 to +140	109	221
330		104	331
470		148	471
680		131	681
1 000		193	102
1 500		187	152
2 200		275	222
3 300		260	332
4 700		369	472
6 800	342	682	
10 000	-20 to +140	405	103
15 000		375	153
22 000		550	223



WIREWOUND POTENTIOMETERS

QUICK REFERENCE DATA

Resistance range (E6-series), linear law	2,2 - 10 000 Ω
Maximum permissible dissipation at 40 °C	2 W
Climatic category (IEC 68)	25/085/21
Plastic housing, plastic spindle	

APPLICATION

In industrial electric and electronic equipment where accurate and gradual resistance regulation and high stability are required.

DESCRIPTION

The potentiometer consists of a single layer of resistance wire wound on an insulated former and housed in a moulded plastic case, which at one end has a plastic cover plate and at the other end a press-fitted threaded metal bushing supporting the plastic spindle.

Terminals a and c (see Fig. 1) are the end terminals which are of a snap-on type; b is the central terminal which is connected to the slider through a collector ring.

The case has a locating slot for mounting purposes.

The potentiometer is dust-proof sealed.



OUTLINES

Dimensions in mm

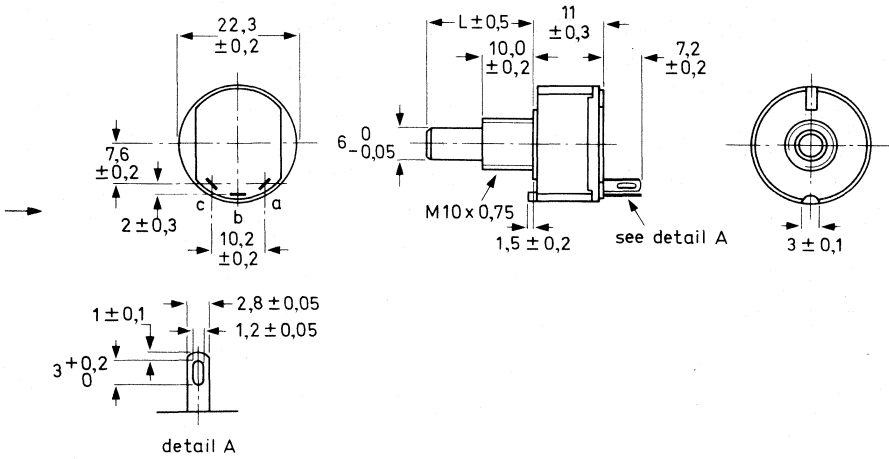

Fig.1a Potentiometer with plain spindle; spindle length L is 17 mm, 20 mm, 30 mm or 60 mm.

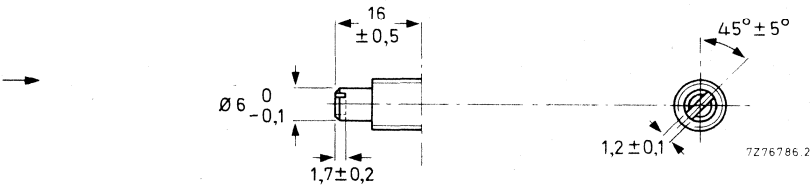

Fig.1b Spindle with screwdriver slot; spindle fully counter clockwise.

MOUNTING

The potentiometer is suitable for central mounting on a panel by means of a nut supplied with the potentiometer (catalogue number of nut 4322 047 00350). The maximum torque for tightening the nut is 3,5 Nm. See Fig.2 for the required mounting holes in the panel. A washer has to be used if the panel thickness is less than 1 mm as otherwise it might not be possible to secure the nut.

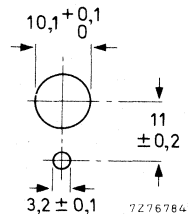

Fig. 2 Mounting holes.

TECHNICAL DATA

Unless stated otherwise, all electrical values have been determined at an ambient temperature of 15 to 25 °C, an air pressure of 930 to 1060 mbar and a relative humidity of 45 to 75%.
 For definitions of properties and test methods, see IEC 393-1.

Nominal resistance value (R_n) between a and c	2,2 to 10 000 Ω , see Table 1
Resistance law	linear
Tolerance on R_n	$\pm 10\%$
Resistance at beginning and end	$\leq 2\%$ of R_{total} or 300 m Ω whichever is greater
R gradient	0% of R_{total}
Resistance at 50% of effective angle of rotation	$50 \pm 2\%$ of R_{total}
Contact resistance between resistance element and slider	$\leq 1\%$ of R_{total} or 200 m Ω whichever is greater
Temperature coefficient	see Table 1
Maximum dissipation between a and c (Fig. 3)	
at $T_{amb} = 40$ °C	2 W
at $T_{amb} = 70$ °C	1,5 W
Resolution	
$R_n = 2,2$ to 68 Ω	$< 1,5\%$ of R_{total}
$R_n > 68$ Ω	$< 0,8\%$ of R_{total}
Maximum slider current	1 A
Maximum working voltage between case and resistance element	500 V (a.c.)
Test voltage between bearing bushing and resistance element	≤ 2000 V (a.c.)
Insulation resistance	> 1000 M Ω
Ambient temperature range	-25 to +85 °C
Storage temperature range	-25 to +85 °C
Mechanical angle of rotation	$270 \pm 5^\circ$
Effective angle of rotation	$265 \pm 5^\circ$
Operating torque	3,5 to 20 mNm
Maximum end stop torque	800 mNm
Maximum axial force (push and pull)	100 N

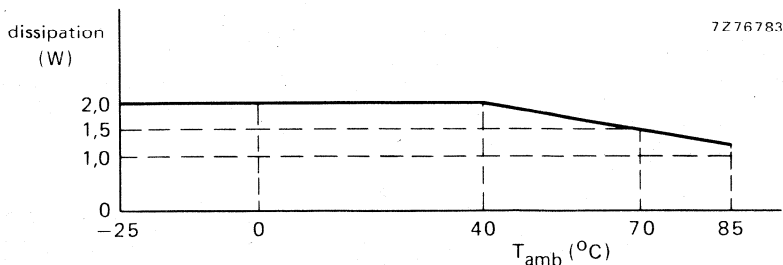

Fig.3 Dissipation as a function of ambient temperature.

Table 1

nominal resistance value Ω	temperature coefficient ppm/°C	number of turns $\pm 25\%$	code in catalogue number
2,2	-25 to +600	110	228
3,3		108	338
4,7		95	478
6,8		136	688
10		126	109
15		194	159
22		113	229
33		134	339
47		120	479
68	-25 to +25	172	689
100		160	101
150		178	151
220	0 to +140	165	221
330		155	331
470		222	471
680		200	681
1000		297	102
1500		287	152
2200		420	222
3300		398	332
→ 4700	-20 to + 20	408	472
→ 6800		366	682
→ 10 000		538	103

MARKING

The potentiometers are marked at the rear with nominal resistance value (according to IEC 62), resistance tolerance, power rating, production code (period and year) and name of manufacturer.

COMPOSITION OF THE CATALOGUE NUMBER

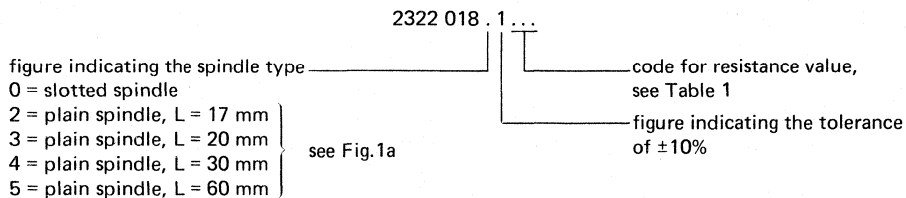

TESTS AND REQUIREMENTS

IEC 393-1 test method	name of test	procedure (quick reference)	requirements
Ta	Solderability	235 ± 2 °C, 2 s.	95% of surface.
Tb (method 1B)	Resistance to soldering heat	350 °C, 3,5 s.	No damage: $\Delta R_{\text{tot}}/R_{\text{tot}} \leq 2\%$.
Na	Rapid change of temperature	5 cycles of ½ h at -25 °C and ½ h at +85 °C.	$\Delta R_{\text{tot}}/R_{\text{tot}} \leq 3\%$.
Fc	Vibration	10 to 55 Hz, 10g, 3 directions, 2 h per direction.	$\Delta R_{\text{tot}}/R_{\text{tot}} \leq 2\%$, 2%. No interruptions > 100 µs.
Ba, D, Aa	Climatic sequence	16 h at 85 °C. 24 h at 55 °C, R.H. 95 to 100%. 2 h at -25 °C. 24 h at 55 °C, R.H. 95 to 100%. 1 h reconditioning at 25 °C	No damage; $R_{\text{min}} \leq 2\%$ R_{tot} ; $\Delta R_{\text{tot}}/R_{\text{tot}} \leq 5\%$. Insulation resistance > 100MΩ. Test voltage for 1 min is 2000 V (a.c.). Continuity of resistance (after 4 cycles): $\Delta V/V < \begin{matrix} +7\% \\ -5\% \end{matrix}$.
Ca	Damp heat	21 days at 40 °C, R.H. 90 to 95%.	$\Delta R_{\text{tot}}/R_{\text{tot}} \leq 5\%$. Continuity of resistance (after 4 cycles): $\Delta V/V < \begin{matrix} +7\% \\ -5\% \end{matrix}$.
	Endurance	1000 h at 70 °C, 1,5 W loaded, 1,5 h in and 0,5 h out.	$\Delta R_{\text{tot}}/R_{\text{tot}} \leq 5\%$. Continuity of resistance (after 4 cycles): $\Delta V/V < \begin{matrix} +7\% \\ -5\% \end{matrix}$.
	Mechanical endurance	15 000 cycles ($R_n \leq 4,7 \text{ k}\Omega$) or 10 000 cycles ($R_n > 4,7 \text{ k}\Omega$), 90% of effective angle of rotation; unloaded.	$\Delta R_{\text{tot}}/R_{\text{tot}} \leq 5\%$. Continuity of resistance (after 4 cycles): $\Delta V/V < \begin{matrix} +7\% \\ -5\% \end{matrix}$.
	Flammability		Self-extinguishing within 15 s after removal from the flame.



WIREWOUND POTENTIOMETERS

QUICK REFERENCE DATA

Resistance range (E6-series), linear law	2,2 - 10 000 Ω
Maximum permissible dissipation at 40 °C	2 W
Climatic category (IEC 68)	25/085/21
Metal housing, metal spindle	

APPLICATION

In professional electric and electronic equipment where accurate and gradual resistance regulation and high stability are required.

DESCRIPTION

The potentiometer consists of a single layer of resistance wire wound on an insulated former and is housed in a metal case which at one end has a plastic cover plate and at the other end a moulded zinc plate with integral threaded bushing and locating pip. The threaded bushing supports the spindle.

Terminals a and c (see Fig. 1) are the end terminals which are of a snap-on type; b is the central terminal which is connected to the slider through a collector ring and is insulated from the spindle.

The potentiometer is dust-proof sealed.



OUTLINES

Dimensions in mm

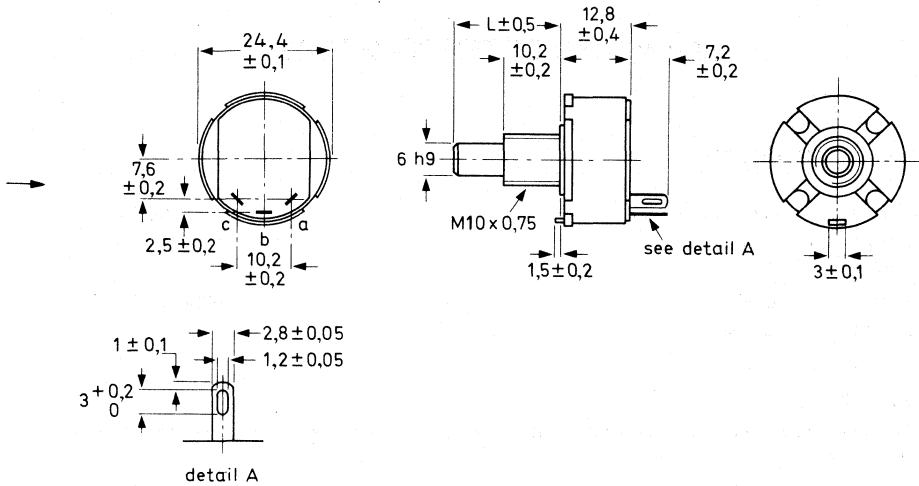

Fig. 1a Potentiometer with plain spindle; spindle length L is 17 mm, 20 mm, 30 mm or 60 mm.

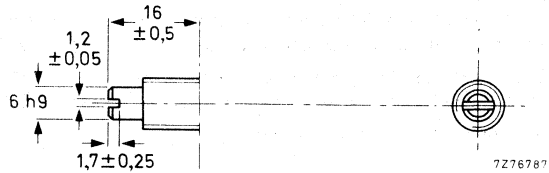

Fig. 1b Spindle with screwdriver slot; position of slot is at random.

MOUNTING

The potentiometer is suitable for central mounting on a panel by means of a nut supplied with the potentiometer (catalogue number of nut 4322 047 00350). The maximum torque for tightening the nut is 3,5 Nm. See Fig.2 for the required mounting holes in the panel.

A washer has to be used if the panel thickness is less than 1 mm as otherwise it might not be possible to secure the nut.

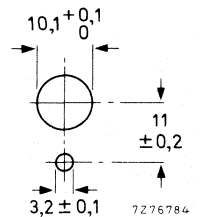

Fig.2 Mounting holes.

TECHNICAL DATA

Unless stated otherwise, all electrical values have been determined at an ambient temperature of 15 to 25 °C, an air pressure of 930 to 1060 mbar and a relative humidity of 45 to 75%. For definitions of properties and test methods, see IEC 393-1.

Nominal resistance value (R_n) between a and c	2,2 to 10 000 Ω , see Table 1
Resistance law	linear
Tolerance on R_n	$\pm 5\%$
Resistance at beginning and end	$< 2\%$ of R_{total} or 300 m Ω whichever is greater
R gradient	0% of R_{total}
Resistance at 50% of effective angle of rotation	$50 \pm 2\%$ of R_{total}
Contact resistance between resistance element and slider	$\leq 1\%$ of R_{total} or 200 m Ω whichever is greater
Temperature coefficient	see Table 1
Maximum dissipation between a and c (Fig. 3)	
at $T_{amb} = 40$ °C	2 W
at $T_{amb} = 70$ °C	1,5 W
Resolution	
$R_n = 2,2$ to 68 Ω	$< 1,5\%$ of R_{total}
$R_n > 68$ Ω	$< 0,8\%$ of R_{total}
Maximum slider current	1 A
Maximum working voltage between case and resistance element	500 V (a.c.)
Test voltage between case and resistance element	≤ 1500 V (a.c.)
Insulation resistance	> 1000 M Ω
Ambient temperature range	-25 to +85 °C
Storage temperature range	-25 to +85 °C
Mechanical angle of rotation	$270 \pm 5^\circ$
Effective angle of rotation	$265 \pm 5^\circ$
Operating torque	7,5 to 20 mNm
Maximum end stop torque	800 mNm
Maximum axial force (push and pull)	100 N

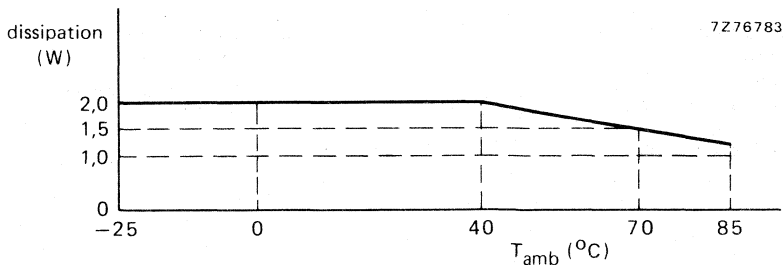

Fig.3 Dissipation as a function of ambient temperature.

Table 1

nominal resistance value Ω	temperature coefficient ppm/°C	number of turns $\pm 25\%$	code in catalogue number
2,2	-25 to +600	110	228
3,3		108	338
4,7		95	478
6,8		136	688
10		126	109
15		194	159
22		113	229
33		134	339
47		120	479
68		-25 to +25	172
100	160		101
150	178		151
220	0 to +140	165	221
330		155	331
470		222	471
680		200	681
1000		297	102
1500		287	152
2200		420	222
3300		398	332
→ 4700	-20 to +20	408	472
→ 6800		366	682
→ 10 000		538	103

MARKING

The potentiometers are marked at the rear with nominal resistance value (according to IEC 62), resistance tolerance, power rating, production code (period and year) and name of manufacturer.

COMPOSITION OF THE CATALOGUE NUMBER

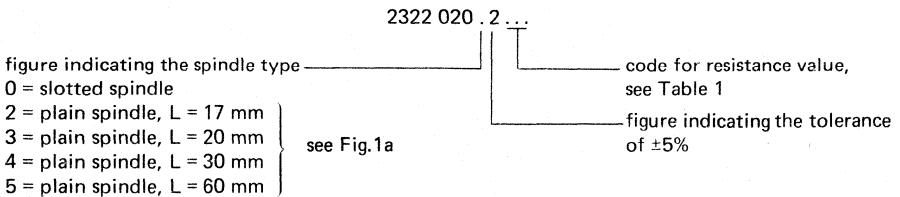

TESTS AND REQUIREMENTS

IEC 393-1 test method	name of test	procedure (quick reference)	requirements
Ta	Solderability	235 ± 2 °C, 2 s.	95% of surface
Tb (method 1B)	Resistance to soldering heat	350 °C, 3,5 s.	No damage; $\Delta R_{tot}/R_{tot} \leq 2\%$.
Na	Rapid change of temperature	5 cycles of ½ h at -25 °C and ½ h at +85 °C.	$\Delta R_{tot}/R_{tot} \leq 3\%$.
Fc	Vibration	10 to 55 Hz, 10g, 3 directions, 2 h per direction.	$\Delta R_{tot}/\Delta R_{tot} \leq 2\%$. No interruptions > 100 µs.
Ba, D, Aa	Climatic sequence	16 h at 85 °C. 24 h at 55 °C, R.H. 95 to 100%. 2 h at -25 °C. 24 h at 55 °C, R.H. 95 to 100%. 1 h reconditioning at 25 °C.	No damage; $R_{min} \leq 2\%$ R_{tot} ; $\Delta R_{tot}/R_{tot} \leq 5\%$. Insulation resistance > 100 MΩ. Test voltage for 1 min is 1500 V (a.c.). Continuity of resistance (after 4 cycles): +7% -5%
Ca	Damp heat	21 days at 40 °C, R.H. 90 to 95%.	$\Delta R_{tot}/R_{tot} \leq 5\%$. Continuity of resistance (after 4 cycles): +7% -5%
	Endurance	1000 h at 70 °C, 1,5 W loaded, 1,5 h in and 0,5 h out.	$\Delta R_{tot}/R_{tot} \leq 5\%$. Continuity of resistance (after 4 cycles): +7% -5%
	Mechanical endurance	15 000 cycles ($R_n \leq 4,7 \text{ k}\Omega$) or 10 000 cycles ($R_n > 4,7 \text{ k}\Omega$), 90% of effective angle of rotation; unloaded.	$\Delta R_{tot}/R_{tot} \leq 5\%$. Continuity of resistance (after 4 cycles): +7% -5%
	Flammability		Self-extinguishing within 15 s after removal from the flame.



LOAD POTENTIOMETERS

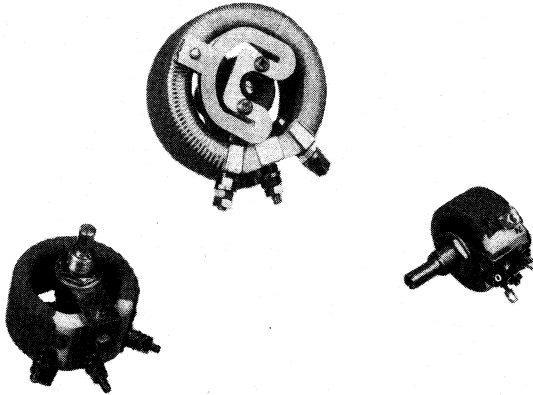

RZ 25706-9

Resistance range
Maximum permissible dissipation at 60 °C

0.5 Ω to 10 kΩ
25, 40, 100 W

APPLICATION

In electric and electronic equipment where current or voltage must be regulated continuously, e.g. control of motor speeds and control of charging current of batteries.

CONSTRUCTION

The potentiometers consist of a ceramic ring A (see figures on next pages) around which a resistance wire or ribbon (consult the Table) has been wound in a single layer - over about 280° in the case of 100 W items, and over about 250° for the other ratings. A terminal B is fitted at each end of the wire or ribbon. With the exception of the top side of the coil, the resistance element is coated with a protective layer of cement which prevents the windings from shifting. The cement is non-inflammable (melting point about 2000 °C).

A carbon brush C is affixed in a double spring-type runner E, the brush being connected to a terminal F through the intermediary of a double sliding-contact. The spring-pressures of the sliding contact and of the carbon brush are independent of each other. In the case of resistance ribbon, the runner of the 40 W and 100 W potentiometers is equipped with an extra spring having a height of 2 and 3 mm, respectively.

By means of an insulating piece G and a central screw H, the runner is affixed to the top of a spindle J which is supported in a sturdy bracket K. A stop prevents the runner from overrunning the track, whereby the runner is not exposed to torsion.

The protrusion N prevents the potentiometers from turning.
 All the metal parts are non-corrosive.

The potentiometers are suitable to be ganged (see section "Ganging").

Dimensions in mm

The spindle length L is 17 or 36 mm.

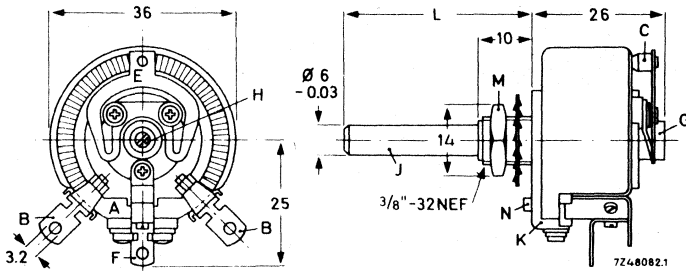

Fig.1. Potentiometers 2322 095 ;
 1 Ω to 7.5 kΩ, 25 W

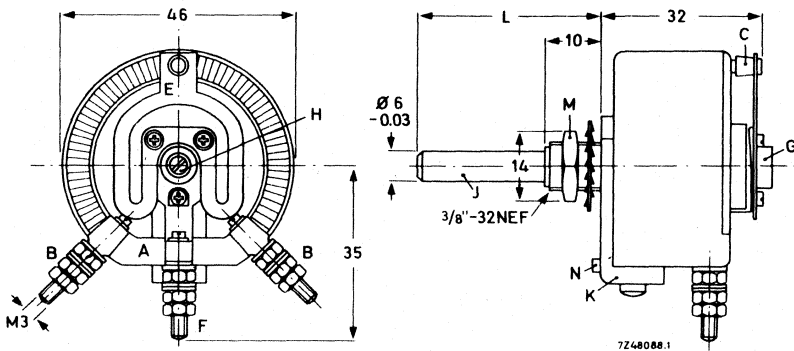

Fig.2. Potentiometers 2322 096 ;
 0.5 Ω to 10 kΩ, 40 W

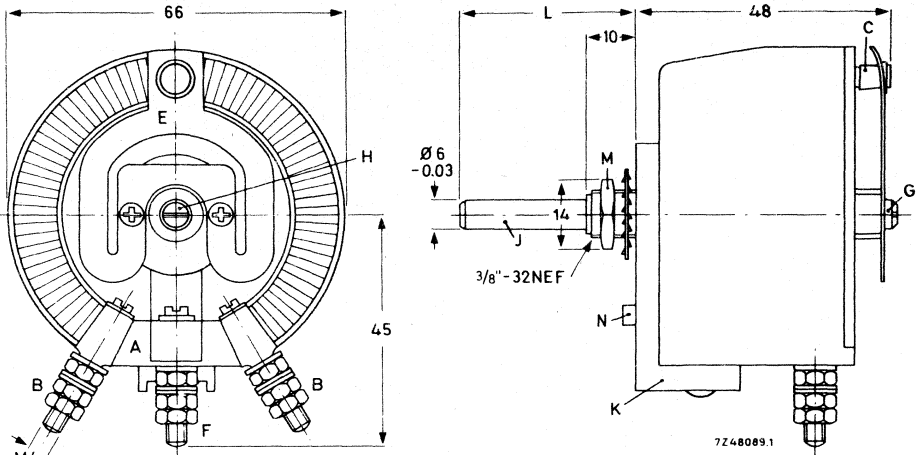

Fig. 3. Potentiometers 2322 097;
0.75 Ω to 10 k Ω , 100 W

Mounting and weight

type	a	b	c	panel thickness maximum	weight g
2322 095	10.5	3.5	13.5	5	60
096	10.5	4.8	20	5	95
097	10.5	4.8	20	5	240

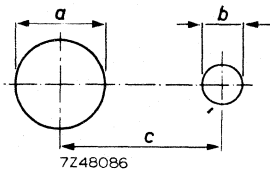

Fig. 4. Holes for mounting with supplied nut, ←
catalogue number 4322 047 00380.

TECHNICAL PERFORMANCE

Nominal resistance values (R_n)
measured between end tags

at $P \leq 0.1 P_n$

Tolerance on R_n

Resistance law

Temperature coefficient of the resistance

Maximum permissible dissipation

at $T_{amb} = 60 \text{ }^\circ\text{C}$ (P_n)

see Table

$\pm 10\%$

linear

$(-140 \text{ to } +140) 10^{-6}/\text{deg C}$

see Table

Maximum permissible current $\sqrt{\frac{P_n}{R}}$
at $T_{amb} = 60\text{ }^\circ\text{C}$ ($I_{max} = \sqrt{\frac{P_n}{R}}$)
at other temperatures

Temperature rise ΔT as f (P)

Working-temperature range

Insulation resistance

Effective angle of rotation

25 W, 40 W types

100 W type

Mechanical angle of rotation

25 W, 40 W types

100 W type

Operating torque

25 W, 40 W types

100 W type

End stop torque

Maximum axial spindle load

Life at maximum current

see Table

see Fig.5

see Fig.6

-55 to +100 °C

> 100 MΩ

250 ± 10°

280 ± 10°

270 ± 5°

300 ± 5°

1 - 4.5 Ncm

8 - 13 Ncm

≤ 200 Ncm

100 Ncm

> 50000 cycles

Fig.5

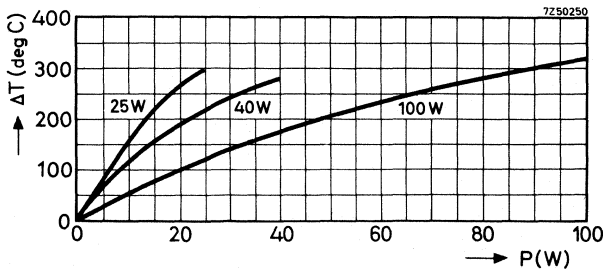
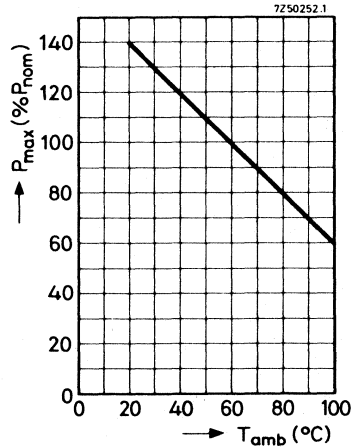

Fig.6

TYPES

Only the types for which I_{max} is listed in the table are available. If I_{max} is stated above the dashed line, the potentiometer is equipped with resistance ribbon.

Table

R_n (Ω)	$P_n = 25$ W		$P_n = 40$ W		$P_n = 100$ W		code in catalog number
	I_{max} (A)	number of windings	I_{max} (A)	number of windings	I_{max} (A)	number of windings	
0.5			8.9	14			507
0.75			7.3	13	11.5	23	757
1	5.0	23	6.3	14	10.0	24	108
1.5	4.0	22	5.15	21	8.15	23	158
2	3.5	23	4.45	28	7.05	24	208
2.5	3.15	22	4.0	23	6.3	32	258
3.5	2.65	23	3.35	28	5.35	42	358
5	2.2	20	2.8	25	4.45	47	508
7.5	1.8	30	2.3	23	3.65	45	758
10	1.55	41	2.0	24	3.15	43	109
15	1.3	39	1.6	27	2.55	40	159
20	1.1	37	1.4	50	2.2	43	209
25	1.0	46	1.25	49	2.0	44	259
35	0.84	60	1.07	49	1.7	75	359
50	0.70	86	0.89	105	1.4	86	509
75	0.58	82	0.73	99	1.15	75	759
100	0.50	109	0.63	132	1.0	143	101
150	0.40	103	0.51	125	0.81	135	151
200	0.35	137	0.44	105	0.70	180	201
250	0.31	108	0.40	132	0.63	142	251
350	0.26	151	0.33	184	0.53	199	351
500	0.22	136	0.28	165	0.44	179	501
750	0.18	204	0.23	157	0.36	268	751
1 000	0.15	172	0.20	210	0.31	226	102
1 500	0.13	258	0.16	214	0.25	340	152
2 000	0.11	345	0.14	286	0.22	286	202
2 500	0.10	272	0.12	357	0.20	357	252
3 500	0.08	380	0.10	392	0.17	316	352
5 000	0.07	343	0.09	417	0.14	450	502
7 500	0.06	513	0.07	395	0.11	428	752
10 000			0.06	528	0.10	570	103

Note - Spare carbon brushes can be supplied under catalog number

- 4322 048 03670 for 25 W types,
- 4322 048 01710 for 40 W types, $R_n \leq 10 \Omega$,
- 4322 048 03530 for 40 W types, $R_n > 10 \Omega$,
- 4322 048 03540 for 100 W types.

COMPOSITION OF THE CATALOG NUMBER

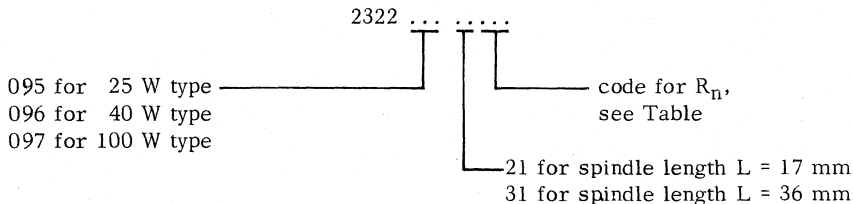

GANGING

For ganging two load potentiometers, sets are available for the coupling of two items and comprising the following parts (see Fig.7), packed in a plastic bag:

- 1 bracket D,
- 1 threaded spindle B,
- 1 cross pin C,
- 1 coupling E,
- 2 set screws K,
- retaining rings

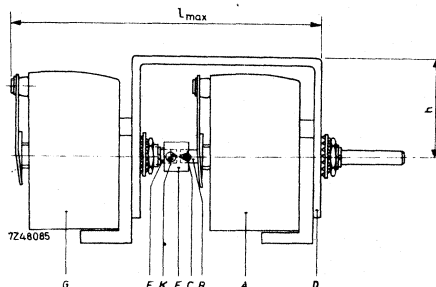

The catalog numbers for ordering these sets and the dimensions are:

potentiometers		catalog number coupling set	l_{max} (mm)	h (mm)
25 W	2322 095 21...	4322 048 06480	83	22
	+ 2322 095			
40 W	2322 096 21...	4322 048 06490	95.5	29.5
	+ 2322 096			
100 W	2322 097 21...	4322 048 06500	129.5	40
	+ 2322 097			

Ganging procedure (see Fig.7)

The central screw H (Figs.1-3) is removed from the potentiometer A and replaced by spindle B having a threaded end that is firmly tightened; the other extremity of B is provided with the round cross-pin C. Thereupon, potentiometer A is attached to the bracket D by means of the hexagonal nut, and coupling E is slipped over the extruding end of B.

The second potentiometer (G) having a spindle (F) with standard length $L = 17$ mm, is now attached to the bracket as well. After placing the runners of both potentiometers in the same position, the coupling is affixed to F by means of the two radial set screws K in the coupling.

When the spindle of potentiometer A is rotated, potentiometer G rotates simultaneously through the intermediary of cross pin C and a V-shaped groove in the coupling. The potentiometers and the coupling should be adjusted so as to obtain a smoothly running assembly.

Mounting

The front face of bracket D is equipped with two 4 mm threaded holes, which allow of fitting two screws through the mounting panel to prevent the ganged assembly from turning when being attached. In this connection, the panel should be provided with apertures according to Fig.8.

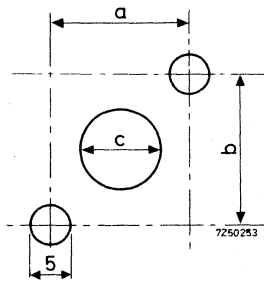

Fig.8

	dimensions in mm			
	a	b	c	panel thickness
25 W	18	20	10.5	≤ 3
40 W	18	30	10.5	≤ 3
100 W	22	30	10.5	≤ 2



INTRODUCTION

There are two main groups in our range of carbon potentiometers.

Preset potentiometers (type indication CTP or CMP) are mainly used for eliminating circuit tolerances during the assembly of electronic equipment or the readjustment of electronic circuits at a later stage.

Four series of preset potentiometers are available:

- CTP18-series: maximum dissipation 0,25 W, dimensions approx. 18 x 20 mm.
- CTP14-series: maximum dissipation 0,2 W, dimensions approx. 14 x 17 mm.
- CTP10-series: maximum dissipation 0,1 W, dimensions approx. 10 x 10 mm.
- CMP-series: rectangular multiturn potentiometers designed for use with television tuners, dimensions approx. 43,5 x 8 x 5 mm.

Control potentiometers (type indication CP or CSP) are widely used in all kinds of electronic equipment, e.g. for volume, tone, brightness and balance control. Six series of control potentiometers are available:

- CP23-series: maximum dissipation 0,25 W (linear law), or 0,125 W (logarithmic law), diameter approx. 23 mm. Single, tandem, twin, and triple types, with or without switch, can be supplied.
- CP16-series: maximum dissipation 0,1 W (linear law), or 0,05 W (logarithmic law), diameter approx. 16 mm. Single and tandem types, with or without switch, can be supplied.
- CP13-series (knob potentiometers): maximum dissipation 0,05 W, diameter approx. 13 mm.
- CSP60-series (slide potentiometers): maximum dissipation 0,4 W (linear law), or 0,2 W (logarithmic law), dimensions approx. 87 x 16 x 10,2 mm. Single and tandem types can be supplied.
- CSP40-series (slide potentiometers): maximum dissipation 0,25 W (linear law), or 0,125 W (logarithmic law), dimensions approx. 68 x 16 x 10,2 mm. Single and tandem types can be supplied.
- CSP25-series (slide potentiometers): dimensions approx. 43,5 x 8 x 5 mm; types with linear or logarithmic law are available.



CARBON POTENTIOMETERS

GLOSSARY OF TERMS

Preset potentiometers — Potentiometers of simple construction, in general without spindle, encapsulation and mounting facilities. They are specially suited for applications where a comparatively small number of movements are required during their life.

Control potentiometers — Potentiometers of more complicated construction, provided with spindle, encapsulation and mounting facilities, and suited for applications where a large number of movements are required during their life.

Single, tandem, twin, triple potentiometers

Single potentiometers are control potentiometers comprising one resistor unit. **Tandem potentiometers** are control potentiometers comprising two identical resistor units controlled by one spindle. **Twin potentiometers** are control potentiometers comprising two resistor units controlled by separate concentric spindles. **Triple potentiometers** are control potentiometers consisting of one single and one tandem potentiometer, controlled by separate concentric spindles.

Switches — Mains-voltage or battery-voltage switches, fitted to the potentiometers and controlled by the potentiometer spindle.

Nominal resistance (R_n) — Nominal value of the resistance between the end terminals a and c (Fig. 1), with the spindle in fully clockwise or counter-clockwise position.

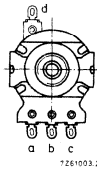
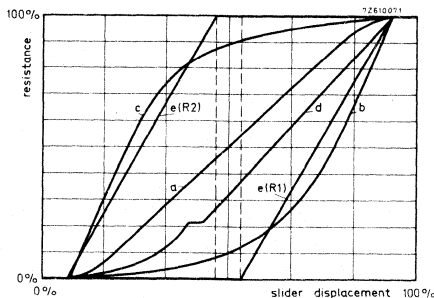

Fig. 1 Potentiometer viewed from the spindle end.

Resistance law — Relation existing between the resistance value measured between the slider terminal (b) and the designated end terminal (a), and the mechanical position of the actuating device (Fig. 2).



a = linear;
b = logarithmic;
c = reversed logarithmic;
d = with tap;
e = balance.

Fig. 2 Resistance laws.

Terminal resistance — Minimum resistance that can be obtained between either end terminals (a or c) and the slider terminal b (see Fig. 3). Where there is no measurable change of resistance between the end stop and the point where the minimum effective resistance is observed, the terminal resistance and the minimum effective resistance become the same.

Minimum resistance at the tap — Minimum adjustable resistance between the tap terminal d (Fig. 1) and the slider terminal b.

Contact resistance (R_c) — Resistance between resistance element and slider contact.

Contact resistance variation (CRV) — Change of the resistance between the resistance element and the slider contact, when it is moved at a defined speed.

Maximum attenuation — Maximum adjustable attenuation when the potentiometer is used as an attenuator (see Fig. 3).

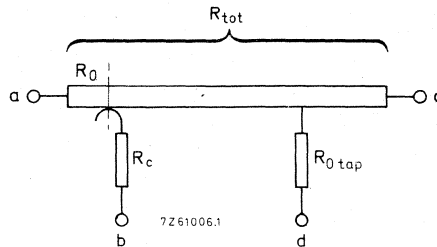

Fig. 3 Diagram of potentiometer; spindle in fully counter-clockwise position.

Terminal resistance: $(R_0 + R_c) \Omega$.

Maximum attenuation: $20 \log \frac{R_0}{R_{tot}}$ dB.

(Voltage between a and b measured currentless; the value of R_c is negligible.)

Maximum dissipation (P_{max}) — Maximum amount of power which can be dissipated at a given ambient temperature, when the potentiometer is continuously loaded between the end terminals a and c (Fig. 1) and mounted on a steel panel of $100 \times 100 \times 1,5$ mm (or on a panel of phenolic paper for types with printed-wiring pins).

Maximum voltage (E_{max}) — The maximum voltage that may be applied is calculated from maximum dissipation (P_{max}) and nominal resistance (R_n): $E_{max} = \sqrt{P_{max} \cdot R_n}$, provided that the limiting element voltage is not exceeded.

Limiting slider current — Maximum current that may be passed between resistance element and slider contact.

Insulation resistance — Resistance measured between interconnected terminals and all other external metal parts.

Test voltage — Voltage to be applied for one minute between interconnected terminals and other external metal parts.

Ganging tolerance — Maximum difference between the adjusted resistances of the two sections of a tandem potentiometer (expressed in dB).

CARBON POTENTIOMETERS

Mechanical angle of rotation — The full extent of the travel of the actuating device between the end stops (Fig. 4).

Effective angle of rotation — That angle throughout which the resistance law is applicable (Fig. 4).

Switching angle — That angle over which the switch has to be actuated from the off to the on position, or vice versa (Fig. 4).

Backlash of the rotary switch — That angle over which the spindle has to be rotated before actuating the switch from the off to the on position (Fig. 4).

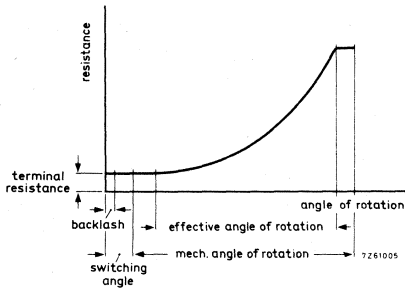

Fig. 4a.

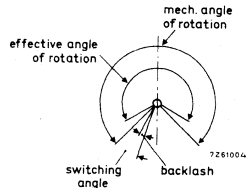

Fig. 4b.

Backlash of potentiometer with push-pull switch — That angle over which the spindle can be rotated before it causes any resistance change.

SURVEY

For ordering use the 12-digit catalogue numbers, see Composition of the catalogue number of the relevant potentiometer.

Potentiometers CP23-series

This series contains single, tandem, twin, and triple * potentiometers. The different switches, terminals, mounting facilities, and spindles are given in the table below.

switch types	terminal types	mounting facilities	spindle types
s.p.s.t. rotary	solder tags	mounting bushing	plain, $\phi 6$ mm
s.p.d.t. rotary	p.w. pins, long	twist tags **	with screwdriver slot ***
d.p.s.t. rotary	p.w. pins, short		with flat face **
d.p.s.t. push-pull			knurled **

Potentiometers CP16-series

This series contains single and tandem * potentiometers. The different switches, terminals, mounting facilities and spindles are given in the table below.

switch types	terminal types	mounting facilities	spindle types
s.p.s.t. rotary (spring actuated)	solder tags	mounting bushing	plain, $\phi 4$ mm
s.p.s.t. rotary (direct operating)	straight p.w. pins, long	twist tags	with screwdriver slot
d.p.s.t. push-pull	straight p.w. pins, short		with flat face
	bent p.w. pins *		knurled

* Only available without switch.

** Not for twin and triple potentiometers.

*** Not for twin and triple potentiometers and for potentiometers with push-pull switch.



16 mm CARBON CONTROL POTENTIOMETERS

QUICK REFERENCE DATA

Resistance range	
linear resistance law	220 Ω - 4,7 M Ω
logarithmic resistance law	1 k Ω - 2,2 M Ω
Maximum dissipation at 40 °C	
linear resistance law	0,1 W
logarithmic resistance law	0,05 W
Climatic category (IEC 68)	10/070/21

RZ28692-3

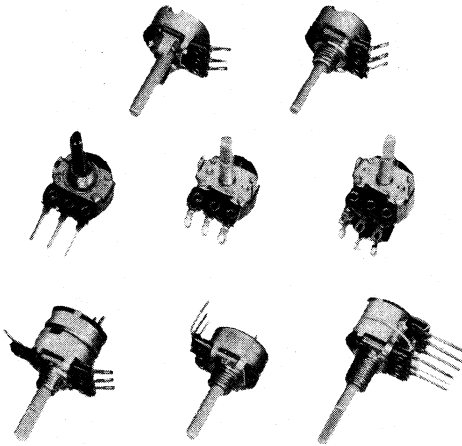

APPLICATION

These potentiometers are widely used in video and audio equipment.

DESCRIPTION

The CP16 carbon control potentiometer series includes two types:

- single potentiometers, for general purposes,
- tandem potentiometers, for stereophonic purposes.

The single potentiometers comprise a carbon track, which is fitted on to a base plate of resin-bonded paper and housed in a metal case. The terminals a and c (see Types) are connected to the ends of the carbon track; terminal b is connected via a contact ring to the slider contact. The potentiometers can be supplied with a tap (d) at 46% (single) or 50% (tandem) of the total mechanical angle of rotation. The potentiometers are provided with plastic or metal spindles.

The tandem potentiometers are composed of two carbon tracks, on base plates of resin-bonded paper, in one housing. The base plates are placed in such a way that the tracks are opposite each other.

→ The single potentiometers can be delivered without switch or with a rotary switch; the tandem potentiometers are only supplied without switch. Both types are available with different connecting terminals, mounting facilities and spindles, see below.

Types

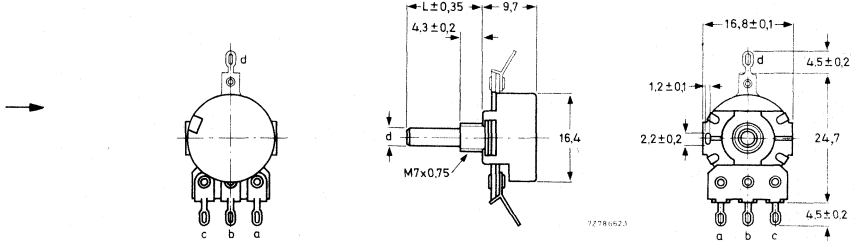

Fig. 1 Single potentiometer with mounting bushing. For dimensions d and L, see Spindles.

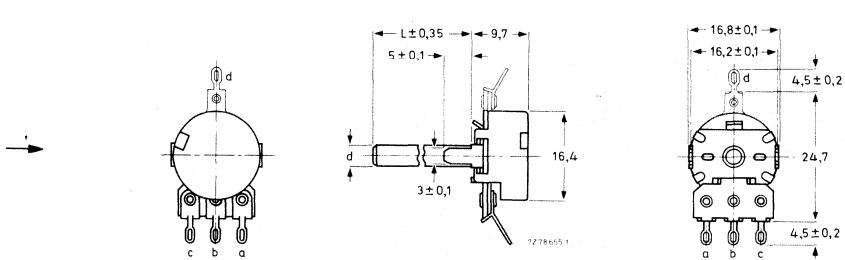

Fig. 2 Single potentiometer with twist tags. For dimensions d and L, see Spindles.

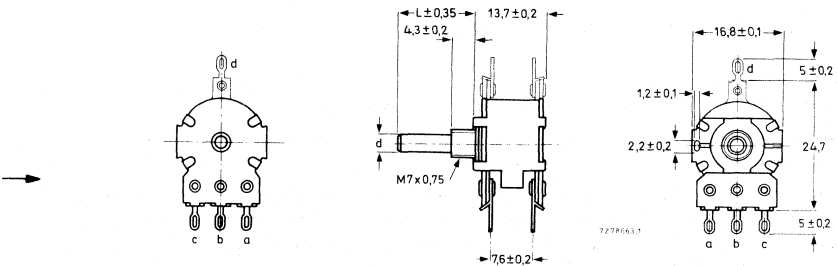

Fig. 3 Tandem potentiometer. For dimensions d and L, see Spindles.

Switches

Single-pole, single-throw, rotary switch (s.p.s.t.).



Fig. 4a Circuit in off-position of spindle (spindle turned fully counter-clockwise).

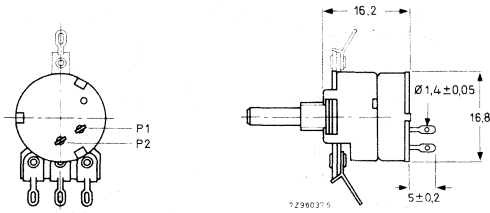

Fig. 4b Single potentiometer with s.p.s.t. rotary switch (spring actuated).

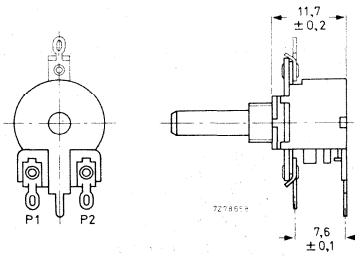

Fig. 4c Single potentiometer with s.p.s.t. rotary switch (direct operating).



Connecting terminals

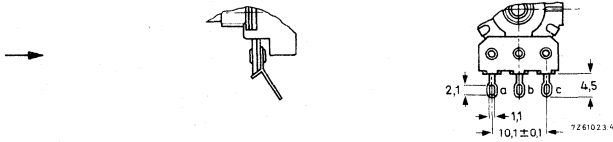

Fig.5 Solder tags.

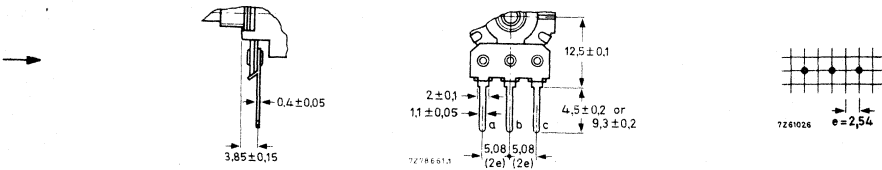

Fig.6 Long or short printed-wiring pins (single potentiometer).

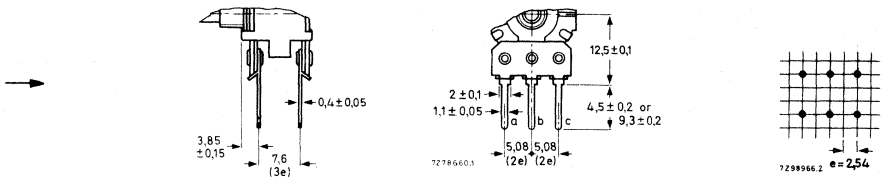

Fig. 7 Long or short printed-wiring pins (tandem potentiometer).

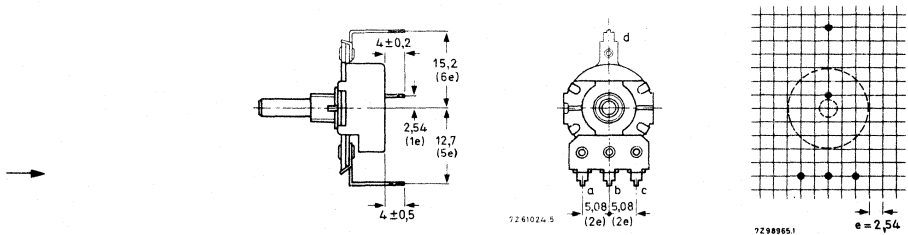
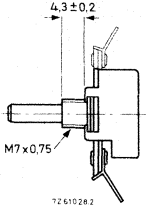
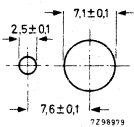
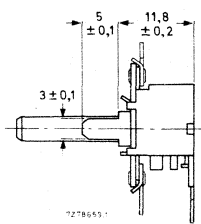
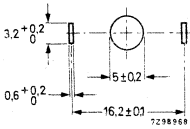
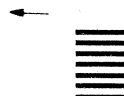

Fig.8 Printed-wiring pins, bent backwards.

Mounting facilities

	required mounting holes in chassis	fixing of potentiometer
<p>mounting bushing M7 x 0,75</p> 		<p>with supplied mounting nut;* max torque for tightening = 1 Nm; min thickness of chassis = 1 mm</p>
<p>twist tags</p> 		<p>by twisting the tags</p> 

* Catalogue number of mounting nut: 4322 047 00370.

Spindles

type	off position	L mm	L ₁ mm	material
		10		metal or plastic
		12		
		15		
		17		
		19		
		20		
		22		
		24		
		25		
		10	3,5	metal or plastic
		15	8,5	
		20	8,5	
		20	13,5	
		10	5	plastic
		15	9	
		20	9	
				metal or plastic

TECHNICAL DATA

Unless otherwise specified, all values have been determined at an ambient temperature of 15 to 35 °C, at atmospheric pressure of 960 to 1060 mbar and a relative humidity of 45 to 75%.

For measuring methods, see IEC publications 190 and 68. For the terms used, the "Glossary of terms" should be consulted.

nominal resistance R_n^*	resistance law according to Figs 9 and 10	max. voltage at 40 °C V	max. terminal resistance	max. attenuation dB	max. contact resistance % R_n	limiting slider current at 40 °C mA
220 Ω	a	4,5	5 Ω	—	4	21
470 Ω	a	7	5 Ω	—	4	14,5
1 k Ω	a	10	5 Ω	—	4	10
2,2 k Ω	a	14	5 Ω	—	4	7
4,7 k Ω	a	22	5 Ω	—	4	5
10 k Ω	a	31	10 Ω	—	4	3,2
22 k Ω	a	45	20 Ω	—	4	2,2
47 k Ω	a	70	35 Ω	—	4	1,5
100 k Ω	a	100	100 Ω	—	4	1,0
220 k Ω	a	140	125 Ω	—	4	0,7
470 k Ω	a	220	250 Ω	—	4	0,5
1 M Ω	a	310	1 k Ω	—	4	0,32
2,2 M Ω	a	460	2 k Ω	—	4	0,22
4,7 M Ω	a	500	5 k Ω	—	4	0,14
1 k Ω	b	7	5 Ω	50	6	7
2,2 k Ω	b	10	5 Ω	50	6	5
4,7 k Ω	b	15	5 Ω	60	6	3,2
10 k Ω	b	22	10 Ω	60	6	2,2
22 k Ω	b	31	20 Ω	60	6	1,5
47 k Ω	b	50	35 Ω	60	6	1,0
100 k Ω	b	70	50 Ω	70	6	0,7
220 k Ω	b	100	50 Ω	80	6	0,5
470 k Ω	b	155	100 Ω	80	6	0,32
1 M Ω	b	220	200 Ω	80	6	0,22
2,2 M Ω	b	310	500 Ω	80	6	0,15

* Measured between terminals a and c; for potentiometers with a tap, between terminals a and d and between c and d.

▲ Measured between terminals a and b; spindle turned fully counter-clockwise.

nominal resistance R_n^*	resistance law according to Figs.9 and 10	max voltage at 40 °C V	max terminal resistance	max attenuation dB	max contact resistance % R_n	limiting slider current at 40 °C mA
1 kΩ	c	7	20 Ω	50 50 60 60 60 70 80 80 80	6	7
2,2 kΩ	c	10	40 Ω			
4,7 kΩ	c	15	100 Ω			
10 kΩ	c	22	200 Ω			
22 kΩ	c	31	250 Ω			
47 kΩ	c	50	500 Ω			
100 kΩ	c	70	2 kΩ			
220 kΩ	c	100	2,5 kΩ			
470 kΩ	c	155	5 kΩ			
1 MΩ	c	220	10 kΩ			
2,2 MΩ	c	310	20 kΩ	80	6	0,15
5 + 42 kΩ	d	50	40 Ω	60	6	1,0
20 + 200 kΩ	d	100	50 Ω	80	6	0,5
50 + 420 kΩ	d	155	470 Ω	80	6	0,32
100 + 900 kΩ	d	220	200 Ω	80	6	0,22
2 + 8 kΩ	e	22	10 Ω	60 60 60 70 80 80	6	2,2
5 + 17 kΩ	e	31	22 Ω			
10 + 37 kΩ	e	50	47 Ω			
20 + 80 kΩ	e	70	100 Ω			
50 + 170 kΩ	e	100	220 Ω			
100 + 370 kΩ	e	155	600 Ω			
0,5 + 1,7 MΩ	e	310	2,2 kΩ			
10 kΩ	f	22	—	—	6	2,2
22 kΩ	f	31	—	—	6	1,5
47 kΩ	f	50	—	—	6	1,0
100 kΩ	f	70	—	—	6	0,7
220 kΩ	f	100	—	—	6	0,5
470 kΩ	f	155	—	—	6	0,32
1 MΩ	f	220	—	—	6	0,22

* Measured between terminals a and c; for potentiometers with a tap, between terminals a and d and between c and d.

† Measured between terminals c and b; spindle turned fully clockwise.

▲ Measured between terminals a and b; spindle turned fully counter-clockwise.

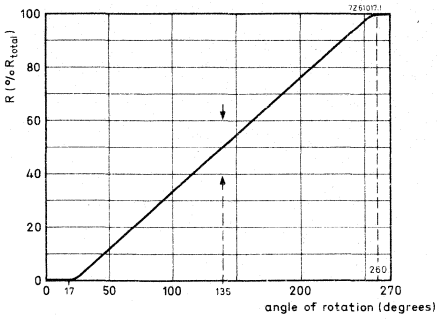

Fig. 9a. Linear resistance law, single potentiometers.

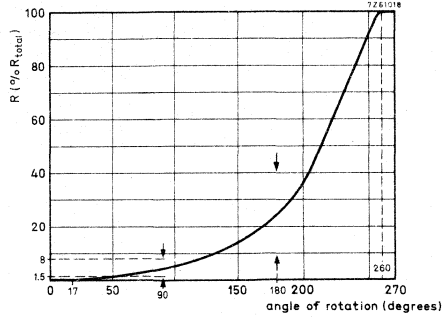

Fig. 9b. Logarithmic resistance law, single potentiometers.

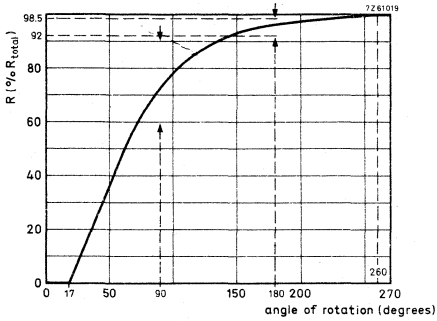

Fig. 9c. Reversed logarithmic resistance law, single potentiometers.

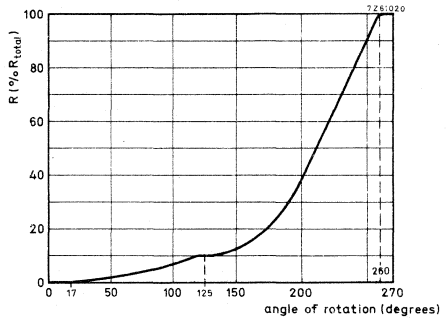

Fig. 9d. Resistance law, tap at 10%, single potentiometers.

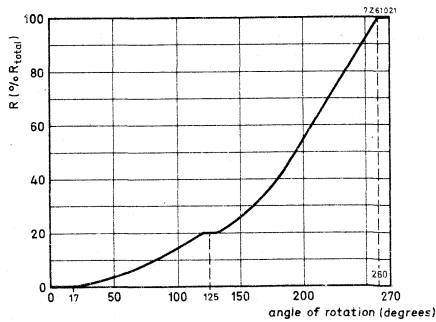

Fig. 9e. Resistance law, tap at 20%, single potentiometers.



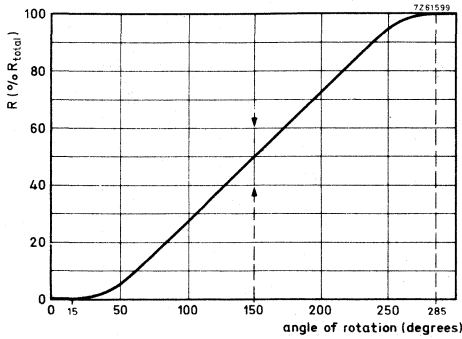

Fig. 10a. Linear resistance law, tandem potentiometers.

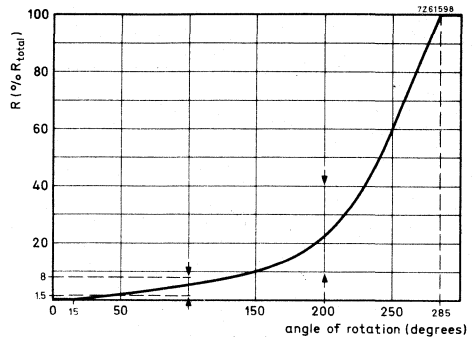

Fig. 10b. Logarithmic resistance law, tandem potentiometers.

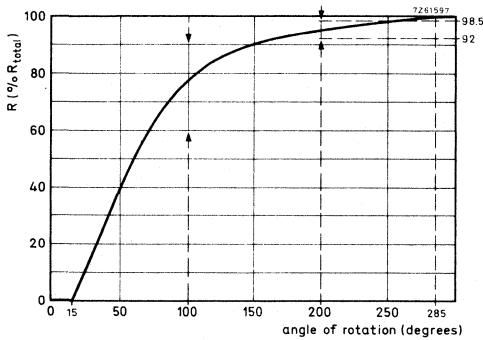

Fig. 10c. Reversed logarithmic resistance law, tandem potentiometers.

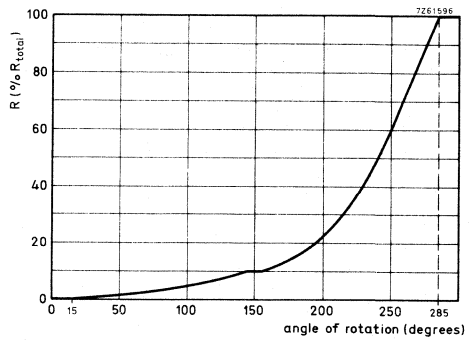

Fig. 10d. Resistance law, tap at 10%, tandem potentiometers.

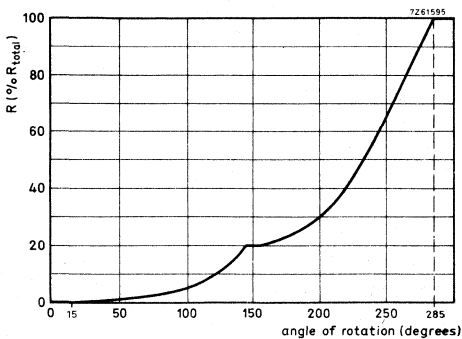

Fig. 10e. Resistance law, tap at 20%, tandem potentiometers.

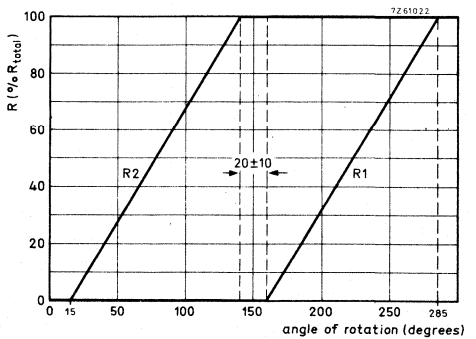

Fig. 10f. Resistance law, balance potentiometers.

Tolerance on the nominal resistance	$\pm 20\%$ ¹⁾	
Resistance law and tolerances	see Figs. 9 and 10	
Ganging tolerance ²⁾		
linear resistance law		
at values between 10 and 90% of R_{total}	< 2 dB	
(reversed) logarithmic resistance law		
at attenuations between 0 and -20 dB	< 2 dB	
at attenuations between -20 and -30 dB	< 3 dB	
at attenuations between -30 and -40 dB	< 4 dB	
with a tap		←
at attenuations between 0 and -20 dB	< 2 dB	
at attenuations between -20 and -30 dB	< 3 dB	
at attenuations between -30 and -34 dB	< 4 dB	
Minimum resistance at the tap	$\leq 1,5\%$ of R_n	
Insulation resistance, initially	> 1000 M Ω	
after damp heat test		
(IEC68, test C, 21 days)	> 25 M Ω	
Maximum dissipation at 40 °C		
linear resistance law, acc. to Figs. 9a, 10a	0,1 W	
resistance law, acc. to Figs. 9b(10b) to 9e (10f)	0,05 W	
Test voltage	1000 V, 50 Hz	
Working temperature range	-10 to $+70$ °C	
Storage temperature range	-25 to $+70$ °C	
Category (IEC68)	10/070/21	
Operating torque	5 to 20 mNm	
Permissible torque with slider at end stop		←
plain spindles	<u>plastic</u> <u>metal</u>	
spindles with flat face	≤ 500 mNm ≤ 600 mNm	
spindles with screwdriver slot	≤ 400 mNm ≤ 600 mNm	
Permissible axial spindle load	≤ 250 mNm ≤ 600 mNm	
single potentiometers	≤ 100 N } pull ≤ 100 N } push	
tandem potentiometers	≤ 100 N } ≤ 60 N }	
Axial spindle play	$< 0,8$ mm	
Radial spindle play, measured with 2,5 N		
at 1 cm from the mounting plane		
potentiometers with mounting bushing	$\leq 0,2$ mm	
potentiometers with twist tags	$\leq 0,5$ mm	
Effective angle of rotation, single	235 - 250°	
tandem	265 - 275°	
balance	range of balance, half the effective angle of rotation: $20 \pm 10^\circ$ $R_2: 125 \pm 10^\circ$ (counter-clockwise) $R_1: 125 \pm 10^\circ$ (clockwise)	

1) For potentiometers with a tap the tolerance on Rad as well as on Rdc = $\pm 20\%$.

2) For tandem potentiometers only.

Mechanical angle of rotation

Single potentiometers, without switch
with switch

tandem potentiometers

$270 \pm 5^\circ$

$292 \pm 5^\circ$

$300 \pm 5^\circ$

Life

after 10 000 cycles ΔR_{total}
< 25% of R_{total}

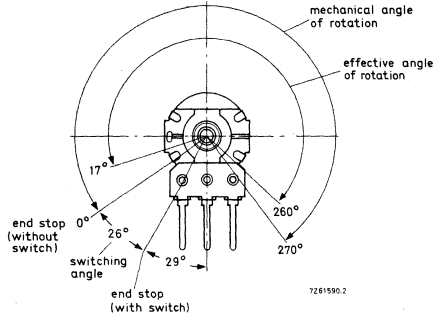

Fig. 11a. Angles of rotation of single potentiometers with or without switch.

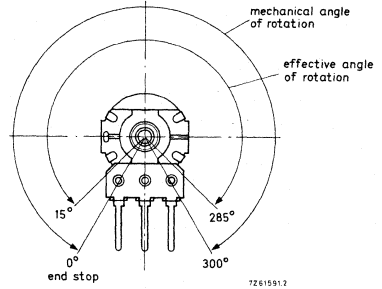

Fig. 11b. Angles of rotation of tandem potentiometers.

	switch type	
	s.p.s.t. rotary spring actuated	s.p.s.t. rotary direct operating
Breaking capacity	12 V d.c., 2 A	12 V d.c., 2 A
Contact resistance, initially after 10 000 on-off switching operations at breaking capacity	< 10 m Ω < 50 m Ω *	< 10 m Ω < 50 m Ω *
Insulation resistance** initially after damp heat test (IEC 68, test C _a , 21 days)	> 10 M Ω > 2 M Ω	> 10 M Ω > 2 M Ω
Test voltage for 1 min**, initially after damp heat test (IEC 68, test C _a , 21 days)	500 V (d.c.) 100 V (d.c.)	500 V (d.c.) 100 V (d.c.)
Switching torque	15 to 40 mNm	12 to 30 mNm
Switching angle	26 \pm 2°	26 \pm 2°
Total mechanical angle of rotation	295 \pm 5°	295 \pm 5°
Backlash	\leq 10°	\leq 10°
Permissible axial spindle load	\leq 100 N	\leq 100 N

MARKING

The potentiometers are marked with the nominal resistance value, resistance law, period and year of manufacture.

* Averaged over 10 measurements: < 25 m Ω .

** Measured between the terminals, and between interconnected terminals and the case or other metal parts.

COMPOSITION OF THE CATALOGUE NUMBER

2322

code for type and switch
without { single = 380
switch { tandem = 390
single, with s.p.s.t.
rotary switch
(spring actuated) 1) = 381

code for terminals, mounting facility,
spindle type and length

solder tags				p. w. pins, length 4, 5 mm				p. w. pins, length 9, 3 mm			
mounting bushing	metal spindle	plastic spindle	twist tags	mounting bushing	metal spindle	plastic spindle	twist tags	mounting bushing	metal spindle	plastic spindle	twist tags
0..	7..	2..	4..	0..	7..	2..	4..	1..	6..	3..	5..

code for resistance law and nominal resistance, see table below

single, with s.p.s.t.
rotary switch
(direct operating) = 387

single, without
switch, with p.w. pins
bent backwards 2) = 389

plain	10 mm = .61	plain	10 mm = .61
	12 mm = .59		12 mm = .59
	15 mm = .62		15 mm = .62
	17 mm = .63		17 mm = .63
	19 mm = .64		19 mm = .64
	20 mm = .65		20 mm = .65
	22 mm = .67		22 mm = .67
	24 mm = .69		24 mm = .69
	25 mm = .51		25 mm = .51
	28 mm = .52		28 mm = .52
30 mm = .53	30 mm = .53		
with flat face	10 (L ₁ = 3,5) mm = .92	with flat face	10 (L ₁ = 3,5) mm = .92
	15 (L ₁ = 8,5) mm = .94		15 (L ₁ = 8,5) mm = .94
	20 (L ₁ = 8,5) mm = .95		20 (L ₁ = 8,5) mm = .95
	20 (L ₁ = 13,5) mm = .96		20 (L ₁ = 13,5) mm = .96
knurled (only plastic)	10 mm = .76	knurled (only plastic)	10 mm = .76
	15 mm = .77		15 mm = .77
	20 mm = .78		20 mm = .78
with screwdriver slot = .60			

1) Only available with mounting bushing.
2) Only available with mounting bushing and p.w. pins of 9, 3 mm length.

nominal resistance	code in catalogue number				nominal resistance	code in catalogue number	
	linear law Figs.9a,10a	log. law Figs.9b,10b	rev. log. law Figs.9c,10c	balance Fig. 10f *		log. law, tap at 10% Figs. 9d, 10d	log. law, tap at 20% Figs.9e,10e
220 Ω	02				5 + 42 kΩ	72	
470 Ω	03				20 + 200 kΩ	67	
1 kΩ	04	24	44		50 + 420 kΩ	73	
2, 2 kΩ	05	25	45		100 + 900 kΩ	64	
4, 7 kΩ	06	26	46		2 + 8 kΩ		76
10 kΩ	07	27	47	91	5 + 17 kΩ		82
22 kΩ	08	28	48	92	10 + 37 kΩ		86
47 kΩ	09	29	49	93	20 + 80 kΩ		77
100 kΩ	11	31	51	94	50 + 170 kΩ		83
220 kΩ	12	32	52	95	100 + 370 kΩ		87
470 kΩ	13	33	53	96	0, 5 + 1, 7 MΩ		84
1 MΩ	14	34	54	97			
2, 2 MΩ	15	35	55				
4, 7 MΩ	16						

NOTE

Detent potentiometers (11 click, 41 click and centre click versions), without switch, can be supplied on request.

* Only for tandem potentiometers.

23 mm CARBON CONTROL POTENTIOMETERS

QUICK REFERENCE DATA

Resistance range	
linear resistance law	220 Ω - 4,7 M Ω
logarithmic resistance law	1 k Ω - 4,7 M Ω
Maximum dissipation at 40 °C	
linear resistance law	0,25 W
logarithmic resistance law	0,125 W
Climatic category (IEC 68)	10/070/21

APPLICATION

The potentiometers are widely used in video and audio equipment.

DESCRIPTION

The CP23 carbon control potentiometer series includes four types:

- single potentiometers, for general purposes;
- tandem potentiometers, for stereophonic purposes;
- twin potentiometers, for combined controls;
- triple potentiometers, for combined stereophonic purposes.

The single potentiometers comprise a carbon track, which is fitted on to a base plate of resin bonded paper and housed in a metal case. The terminals a and c (see Types) are connected to the ends of the carbon track; terminal b is connected via a contact ring to the slider contact. The potentiometers can be supplied with a tap (d) at 40% of the total mechanical angle of rotation. The material of the spindle is plastic.

The tandem potentiometers are composed of two single potentiometers which are ganged; their resistance values and gradings are identical within narrow limits.

The twin potentiometers are composed of two single potentiometers R₁ and R₂; potentiometer R₁ is operated by means of a hollow steel spindle or a hollow plastic spindle, through which a steel spindle protrudes for the operation of potentiometer R₂.

The triple potentiometers consist of one single potentiometer (R₁) and one tandem potentiometer (R₂ and R₃); operation is done as for the twin potentiometers.

Single, tandem and twin potentiometers can be delivered without switch, with rotary switch or with a push-pull switch; triple potentiometers are only available without switch.

Single and tandem potentiometers are available with different connecting terminals, mounting facilities and spindles.

Types

For dimensions d, L and L₁, see Spindles.

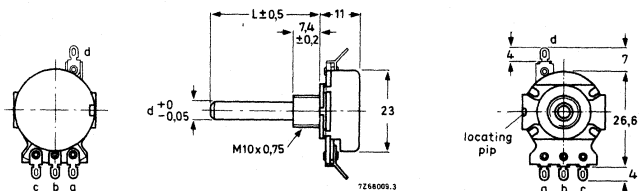

Fig. 1a Single potentiometer with mounting bushing.

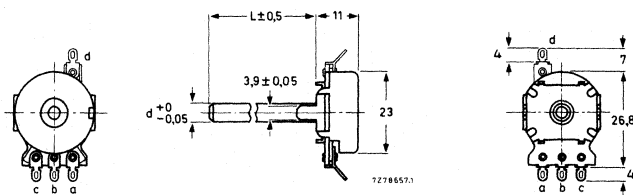

Fig. 1b Single potentiometer with twist tags.

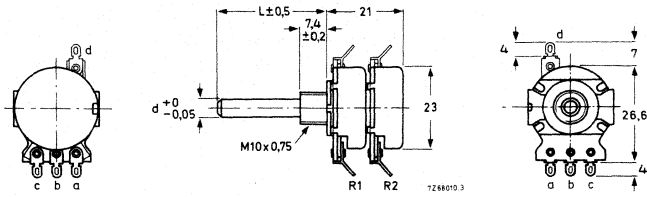

Fig. 2 Tandem potentiometer.

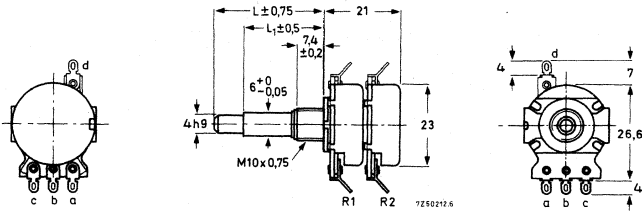

Fig. 3 Twin potentiometer.

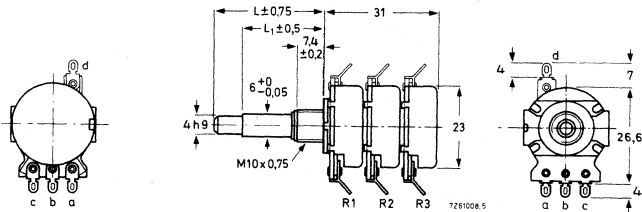

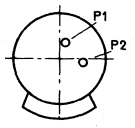

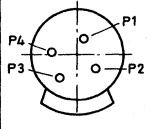

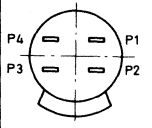

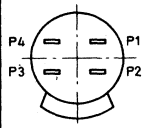

Fig. 4 Triple potentiometer.

Switches

type	circuit in "off"-position of spindle ¹⁾	position of terminals	Fig.	available with potentiometer type
single-pole, single-throw rotary switch (s. p. s. t.)	 <p style="text-align: center;">7260999</p>		5 6 6	single tandem twin
single-pole, double-throw rotary switch (s. p. d. t.)	 <p style="text-align: center;">7261000</p>		7 8	single tandem twin
double-pole, single-throw rotary switch (d. p. s. t.)	 <p style="text-align: center;">7261001</p>		9 10 10	single tandem twin
double-pole, single-throw push-pull switch 2A (d. p. s. t.)	 <p style="text-align: center;">7261001</p>		11 12 12	single tandem twin

¹⁾ Spindle turned fully counterclockwise for rotary switches or pushed in for push-pull switches.

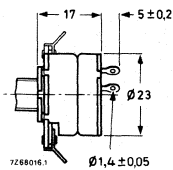

Fig. 5. S.P.S.T. rotary switch (single potentiometer).

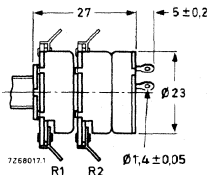

Fig. 6. S.P.S.T. rotary switch (tandem or twin potentiometer).

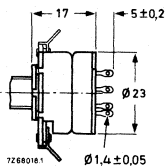

Fig. 7. S.P.D.T. rotary switch (single potentiometer).

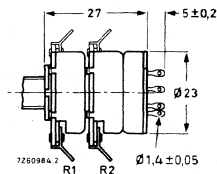

Fig. 8. S.P.D.T. rotary switch (tandem potentiometer).

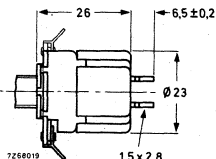

Fig. 9. D.P.S.T. rotary switch (single potentiometer).

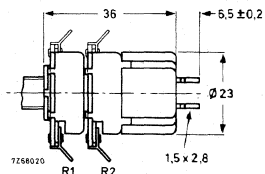

Fig. 10. D.P.S.T. rotary switch (tandem or twin potentiometer).

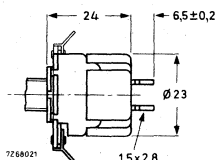

Fig. 11. D.P.S.T. push-pull switch (single potentiometer).

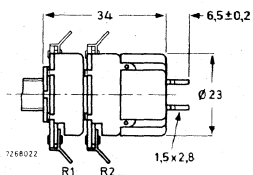

Fig. 12. D.P.S.T. push-pull switch (tandem or twin potentiometer).

Connecting terminals

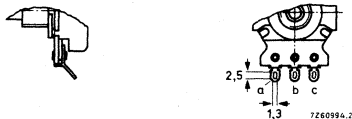

Fig. 13 Solder tags.

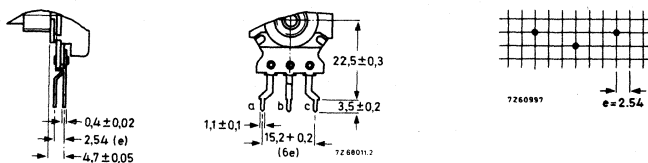

Fig. 14 Long printed-wiring pins, pin distance 15,2 mm (6e) (single potentiometer). ¹⁾

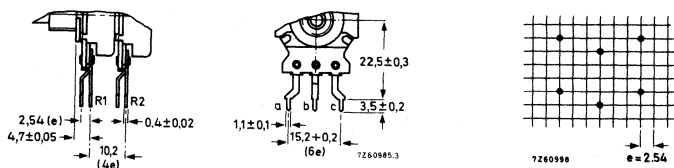

Fig. 15 Long printed-wiring pins, pin distance 15,2 mm (6e) (tandem potentiometer). ¹⁾

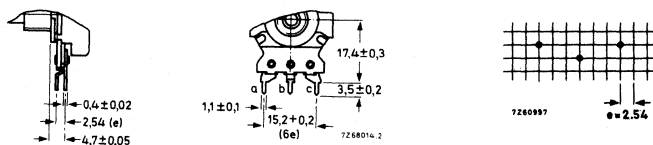

Fig. 16 Short printed-wiring pins, pin distance 15,2 mm (6e) (single potentiometer). ¹⁾

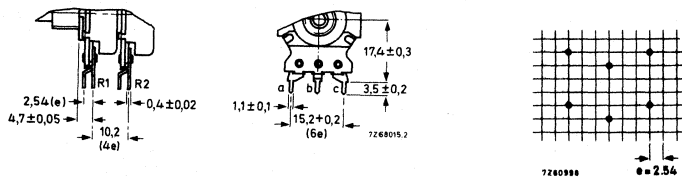

Fig. 17 Short printed-wiring pins, pin distance 15,2 mm (6e) (tandem potentiometer). ¹⁾

¹⁾ Twin and triple potentiometers with printed-wiring pins are available on request.

Mounting facilities

mounting facility

required mounting holes in chassis fixing of potentiometer

mounting bushing
M10 x 0,75

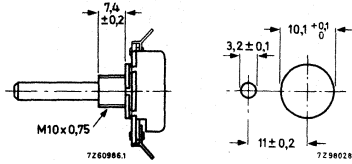

with supplied mounting nut ¹⁾;
max. torque for tightening = 3,5 Nm;
min. thickness of chassis = 1,5 mm

Fig. 18

twist tags
Note - Not for twin and triple potentiometers

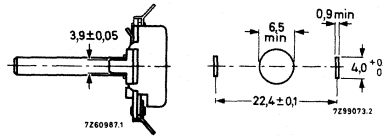

by twisting the tags

Fig. 19

¹⁾ Catalogue number of mounting nut: 4322 047 00350.

Spindles

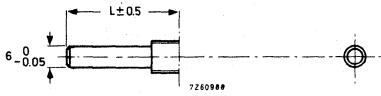
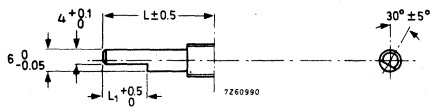
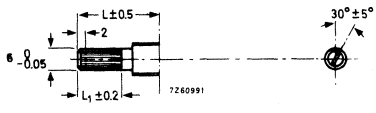
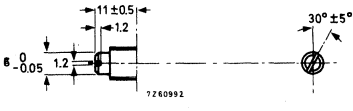
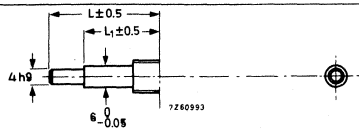
type	"off position"	L (mm)	L ₁ (mm)	available with potentiometer type
		17		} single tandem
		18		
		19		
		20		
		22		
		25		
		30		
		35		
		40		
		60		
	70			
	90			
		18	8.5	} single tandem
		25	13.5	
		28	13.5	
		30	13.5	
		35	13.5	
		40	13.5	
		60	13.5	
		70	13.5	
	90	13.5		
		18	8	} single tandem
		30	12	
		60	12	
				single tandem (not for potentiometers with push-pull switch)
		30.5	18	} twin triple
		42.5	30	

→ Note- For potentiometers with push-pull switch the length L applies to "off-position" of switch.

TECHNICAL DATA

Unless otherwise specified, all values have been determined at an ambient temperature of 15 to 35 °C, an atmospheric pressure of 860 to 1060 mbar and a relative humidity of 45 to 75%.

For measuring methods, see IEC publications 190 and 68. For the terms used, the Glossary of terms should be consulted.

nominal resistance R_n^*	resistance law according to Fig. 20	max voltage (V)		max terminal resistance	max attenuation dB	max contact resist. % R_n	limiting slider current at 40 °C mA
		at 40 °C	at 70 °C				
220 Ω	a	7,4	5,7	10 Ω	—	3	40
330 Ω	a	8,7	6,7	10 Ω	—	3	30
470 Ω	a	11	8,4	10 Ω	—	3	22
1 kΩ	a	16	12	25 Ω	—	3	16
2,2 kΩ	a	23	18	25 Ω	—	3	11
4,7 kΩ	a	34	26	25 Ω	—	3	7
10 kΩ	a	50	39	35 Ω	—	2,5	5
22 kΩ	a	74	57	35 Ω	—	2,5	3,5
47 kΩ	a	110	84	35 Ω	—	2,5	2,2
100 kΩ	a	160	120	100 Ω	—	2,5	1,4
220 kΩ	a	230	180	125 Ω	—	2,5	1,0
470 kΩ	a	340	265	250 Ω	—	2,5	0,65
1 kΩ	a	500	390	1 kΩ	—	2,5	0,45
2,2 MΩ	a	500	500	2,2 kΩ	—	2,5	0,32
4,7 MΩ	a	500	500	4,7 kΩ	—	2,5	0,22
470 Ω	b	8,4	6,9	5 Ω	—	6	14
1 kΩ	b	12	10	5 Ω	50	4	10
2,2 kΩ	b	18	15	5 Ω	60	4	7
4,7 kΩ	b	26	22	5 Ω	60	4	4,5
10 kΩ	b	39	32	10 Ω	60	4	3,2
22 kΩ	b	57	47	22 Ω	60	4	2,2
47 kΩ	b	84	69	35 Ω	70	4	1,4
100 kΩ	b	120	100	50 Ω	70	4	1,0
220 kΩ	b	180	150	50 Ω	80	4	0,7
470 kΩ	b	265	220	100 Ω	80	4	0,45
1 MΩ	b	390	320	500 Ω	80	4	0,32
2,2 MΩ	b	500	470	2,2 kΩ	80	4	0,22

* Measured between terminals a and c; for potentiometers with a tap, between terminals a and d and between c and d.

▲ Measured between terminals a and b; spindle turned fully counter-clockwise.

nominal resistance R_n^*	resistance law according to Fig.20	max voltage (V)		max terminal resistance	max attenuation dB	max contact resist. % R_n	limiting slider current at 40 °C mA
		at 40 °C	at 70 °C				
330 Ω	c	6,7	5,5	20 Ω	—	6	20
470 Ω	c	8,4	6,9	20 Ω	—	6	14
1 k Ω	c	12	10	50 Ω	50	4	10
2,2 k Ω	c	18	15	50 Ω	60	4	7
4,7 k Ω	c	26	22	100 Ω	60	4	4,5
10 k Ω	c	39	32	200 Ω	60	4	3,2
22 k Ω	c	57	47	250 Ω	60	4	2,2
47 k Ω	c	84	69	500 Ω	70	4	1,4
100 k Ω	c	120	100	2 k Ω	70	4	1,0
220 k Ω	c	180	150	2,5 k Ω	80	4	0,7
470 k Ω	c	260	220	5 k Ω	80	4	0,45
1 M Ω	c	390	320	20 k Ω	80	4	0,32
2,2 M Ω	c	500	470	44 k Ω	80	4	0,22
20 + 200 k Ω	d	180	150	50 Ω	80	4	0,7
50 + 420 k Ω	d	265	220	100 Ω	80	4	0,45
100 + 900 k Ω	d	390	320	500 Ω	80	4	0,32
0,2 + 2 M Ω	d	500	470	2,2 k Ω	80	4	0,22
0,5 + 1,7 k Ω	e	18	15	5 Ω	60	4	7
5 + 17 k Ω	e	57	47	22 Ω	60	4	2,2
10 + 37 k Ω	e	84	69	47 Ω	70	4	1,4
20 + 80 k Ω	e	120	100	100 Ω	70	4	1,0
50 + 170 k Ω	e	180	150	220 Ω	80	4	0,7
100 + 370 k Ω	e	265	220	470 Ω	80	4	0,45
200 + 800 k Ω	e	390	320	1 k Ω	80	4	0,32
0,5 + 1,7 M Ω	e	500	470	2,2 k Ω	80	4	0,22
400 + 600 k Ω	f	500	390	1 k Ω	60	2,5	0,45
200 + 100 k Ω	g	210	170	3 k Ω	—	4	0,7
22 k Ω	h	50	35	—	—	4	3,5
47 k Ω	h	80	55	—	—	4	2,2
100 k Ω	h	110	80	—	—	4	1,4
220 k Ω	h	160	110	—	—	4	1,0
470 k Ω	h	250	175	—	—	4	0,65
1 M Ω	h	350	250	—	—	4	0,45

* Measured between terminals a and c; for potentiometers with a tap, between terminals a and d and between c and d.

† Measured between terminals c and b; spindle turned fully clockwise.

▲ Measured between terminals a and b; spindle turned fully counter-clockwise.

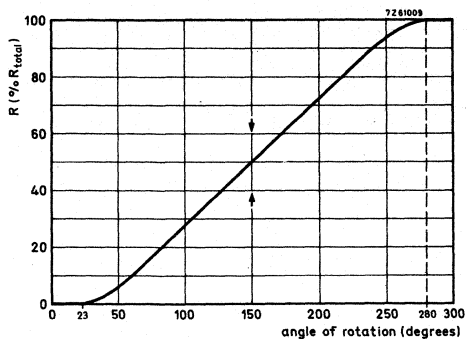

Fig. 20a. Linear resistance law.

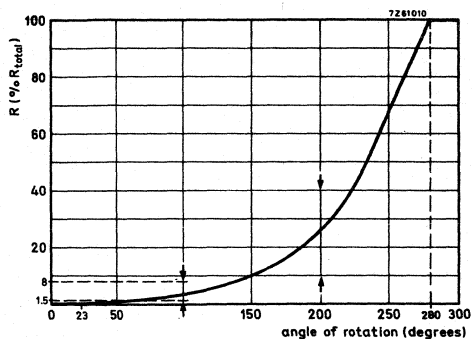

Fig. 20b. Logarithmic resistance law.

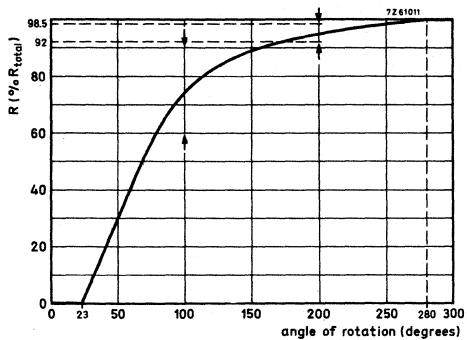

Fig. 20c. Reversed logarithmic resistance law.

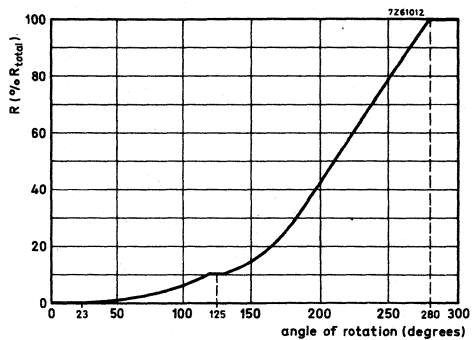

Fig. 20d. Resistance law, tap at 10%.

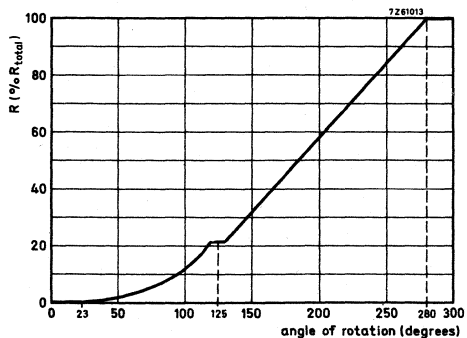

Fig. 20e. Resistance law, tap at 20%.

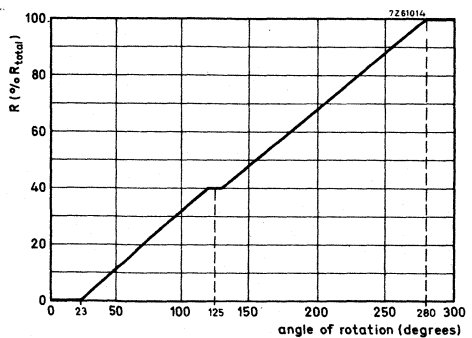

Fig. 20f. Linear resistance law, tap at 40%.

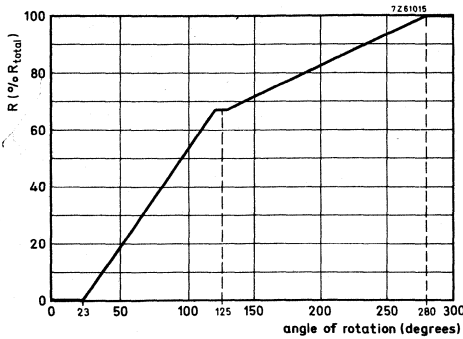

Fig. 20g. Linear resistance law, tap at 67%.

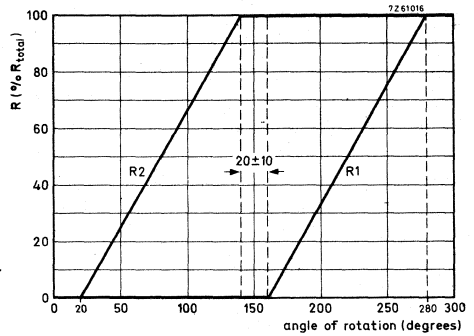

Fig. 20h. Resistance law, balance potentiometers.

Tolerance on the nominal resistance
Resistance law and tolerances
Ganging tolerance 2)

linear resistance law

at values between 10 and 90% of R_{total}
with a tap at 40% and

at attenuations between 0 and -20 dB

at attenuations between -20 and -28 dB

(reversed) logarithmic resistance law

at attenuations between 0 and -20 dB

at attenuations between -20 and -30 dB

at attenuations between -30 and -40 dB

with a tap at 10% or 20% and

at attenuations between 0 and -20 dB

at attenuations between -20 and -30 dB

at attenuations between -30 and -34 dB

Minimum resistance at the tap

Insulation resistance after damp heat test
(IEC 68, test C, 21 days)

Maximum dissipation

linear resistance law, acc. to Fig. 20a, at 40 °C
at 70 °C

resistance law, acc. to Figs. 20b to 20h, at 40 °C
at 70 °C

Test voltage

Working-temperature range

Category (IEC 68)

Operating torque

single- and twin potentiometers

tandem- and triple potentiometers

Permissible torque with slider at end stop

Permissible axial spindle load

$\pm 20\% 1)$

see Figs. 20a to 20h

< 2 dB

< 2 dB

< 3 dB

< 2 dB

< 3 dB

< 4 dB

< 2 dB

< 3 dB

< 4 dB

$\leq 1\%$ of R_n

> 100 M Ω

0.25 W

0.125 W

0.125 W

0.0625 W

1000 V, 50 Hz

-10 to +70 °C

10/070/21

0.3 - 2 Ncm

0.7 - 3.5 Ncm

≤ 80 Ncm

≤ 100 N

1) For potentiometers with a tap the tolerance on R_1 as well as on R_2 is $\pm 20\%$.

2) For tandem and triple potentiometers only.

Effective angle of rotation
 Mechanical angle of rotation
 Life

250 - 265°
 300 ± 5°
 after 10000 rotations
 $\Delta R_{total} < 25\%$ of R_{total}

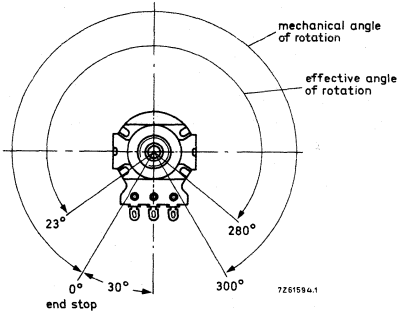

Fig. 21a. Angles of rotation of potentiometers without switch or with a push-pull switch.

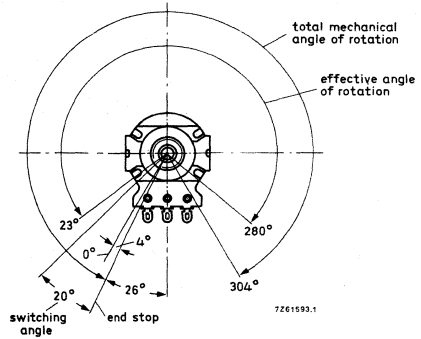

Fig. 21b. Angles of rotation of potentiometers with a s.p.s.t. rotary switch.

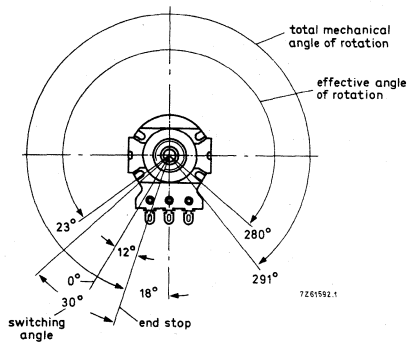

Fig. 21c. Angles of rotation of potentiometers with a d.p.s.t. rotary switch.

MARKING

The potentiometers are marked with the nominal resistance value, resistance law, period and year of manufacture.

	switch type			
	rotary s.p.s.t.	rotary s.p.d.t.	rotary d.p.s.t.	push-pull d.p.s.t., 2A
Approved by	C.S.A.	C.S.A.	C.S.A., E.I., S.E.V., Demko, Semko, Nemko	Demko, Semko, Nemko
Breaking capacity	250Va.c., 0,5A, cos φ = 0,9 125Va.c., 1A, cos φ = 0,9	250Va.c., 0,5A, cos φ = 0,9 125Va.c., 1A, cos φ = 0,9	250 Va.c., 1,5 A/32x (IEC 65)	250 Va.c., 2 A/32x (IEC 65)
Contact resistance, initially after damp heat test (IEC 68, test C, 21 days) after 10000 on-off switching operations at breaking capacity	< 25 mΩ < 40 mΩ ≤ 200 mΩ ²⁾	< 25 mΩ < 40 mΩ ≤ 200 mΩ ²⁾	< 20 mΩ ¹⁾ < 40 mΩ ≤ 200 mΩ ²⁾	< 20 mΩ ¹⁾ < 40 mΩ ≤ 200 mΩ ²⁾
Insulation resistance, initially after damp heat test (IEC 68, test C, 21 days)	> 100 MΩ > 2 MΩ	> 100 MΩ > 2 MΩ	> 5000 MΩ > 25 MΩ	> 5000 MΩ > 25 MΩ
Test voltage ⁵⁾ , initially after damp heat test (IEC 68, test C, 21 days) ⁶⁾	2000 V, 50 Hz 500 V, 50 Hz	2000 V, 50 Hz 500 V, 50 Hz	2000 V, 50 Hz 2000 V, 50 Hz	2200 V, 50 Hz 2200 V, 50 Hz
Switching torque	4 - 8 Ncm ³⁾ 4 - 9,5 Ncm ⁴⁾	4 - 8 Ncm ³⁾ 4 - 9,5 Ncm ⁴⁾	4 - 8 Ncm ³⁾ 4 - 9,5 Ncm ⁴⁾	3,5 - 4,5 N
Switching force	20 ± 2 ⁰	20 ± 2 ⁰	25 - 35 ⁰	3,5 mm
Switching angle Switching stroke	308 ± 5 ⁰	308 ± 5 ⁰	303 ± 5 ⁰	300 ± 5 ⁰
Total mechanical angle of rotation	≤ 6 ⁰	≤ 6 ⁰	-	≤ 9 ⁰
Backlash (rotary switch)	≤ 100N	≤ 100N	≤ 100N	≤ 100N
Backlash (push-pull switch)	≤ 100N	≤ 100N	≤ 100N	≤ 100N
Permissible axial spindle load	≤ 100N	≤ 100N	≤ 100N	≤ 100N

¹⁾ Measured per contact (e.g. between P1 and P2, see "Switches").

²⁾ Averaged over 10 measurements: ≤ 100 mΩ.

³⁾ For single and twin potentiometers.

⁴⁾ For tandem potentiometers.

⁵⁾ Measured at opened switch between the terminals, and between the case or spindle and interconnected terminals.

⁶⁾ Measured after recovery period of 24 hours.

COMPOSITION OF THE CATALOGUE NUMBER Single and tandem types

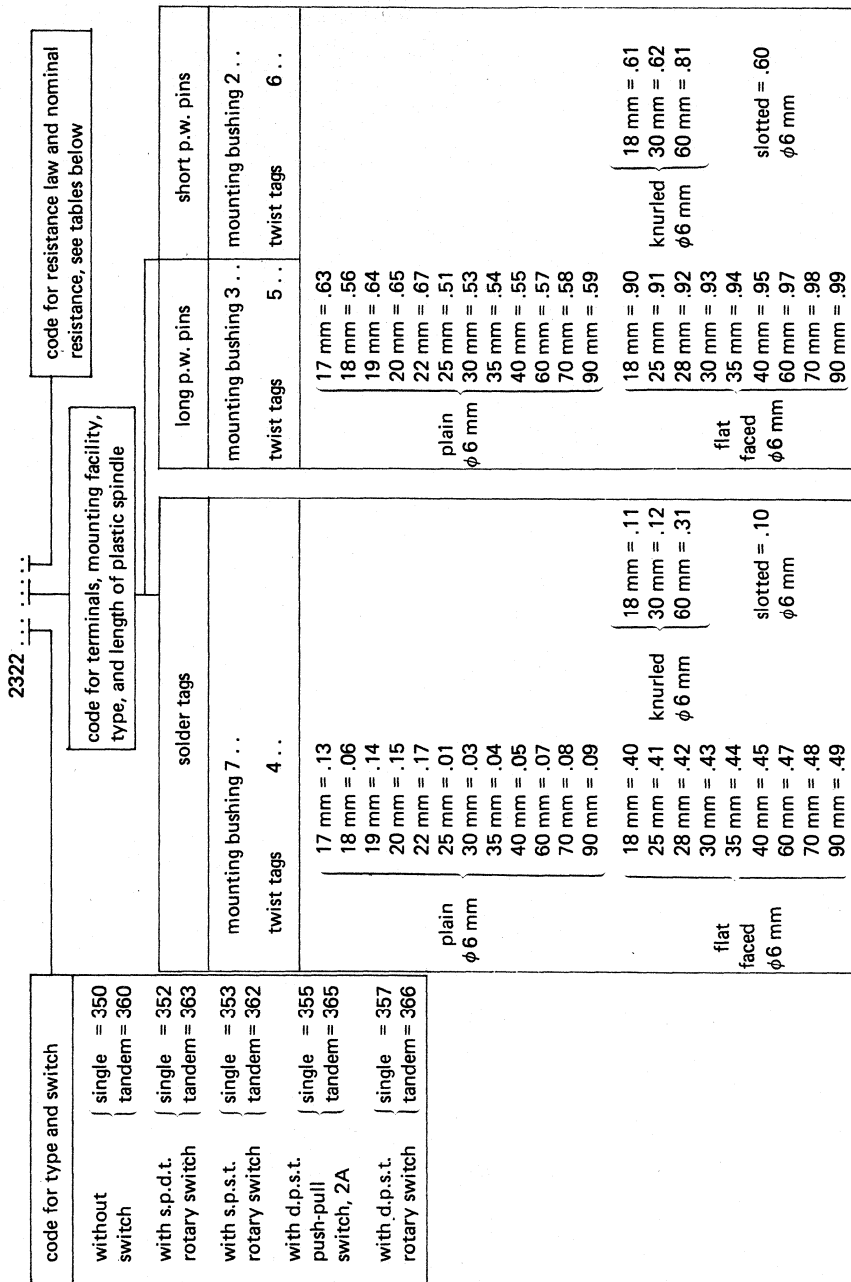



Twin and triple types

2322

code for type, switch and hollow spindle

steel hollow spindle		plastic hollow spindle	
without switch	{ twin = 370 triple = 378 }	without switch	{ twin = 470 triple = 478 }
with s.p.d.t. rotary switch	{ twin = 372 }	with s.p.d.t. rotary switch	{ twin = 472 }
with s.p.s.t. rotary switch	{ twin = 373 }	with s.p.s.t. rotary switch	{ twin = 473 }
with d.p.s.t. push-pull switch, 2A	{ twin = 375 }	with d.p.s.t. push-pull switch, 2A	{ twin = 475 }
with d.p.s.t. rotary switch	{ twin = 376 }	with d.p.s.t. rotary switch	{ twin = 476 }

code for resistance law and nominal resistance of potentiometer R₂, see tables below

code for resistance law and nominal resistance of potentiometer R₁, see tables below

code for spindle lengths

plastic hollow spindle
18 and 30.5 mm = 0
30 and 42.5 mm = 1

steel hollow spindle
18 and 30.5 mm = 6
30 and 42.5 mm = 7

nominal resistance	code in catalogue number			
	log. law tap at 10% Fig. 20d	log. law tap at 20% Fig. 20e	lin. law tap at 40% Fig. 20f	lin. law tap at 67% Fig. 20g
20 + 200 k Ω	67			
50 + 420 k Ω	73			
100 + 900 k Ω	64			
0,2 + 2 M Ω	68			
0,5 + 1,7 k Ω		81		
5 + 17 k Ω		82		
10 + 37 k Ω		86		
20 + 80 k Ω		77		
50 + 170 k Ω		83		
100 + 370 k Ω		87		
200 + 800 k Ω		78		
0,5 + 1,7 M Ω		84		
400 + 600 k Ω			89	
200 + 100 k Ω				65

nominal resistance	code in catalogue number			
	lin. law Fig. 20a	log. law Fig. 20b	rev. log. law Fig. 20c	balance Fig. 20h
220 Ω	02			
330 Ω	19		59	
470 Ω	03	23	43	
1 k Ω	04	24	44	
2,2 k Ω	05	25	45	
4,7 k Ω	06	26	46	
10 k Ω	07	27	47	
22 k Ω	08	28	48	92
47 k Ω	09	29	49	93
100 k Ω	11	31	51	94
220 k Ω	12	32	52	95
470 k Ω	13	33	53	96
1 M Ω	14	34	54	97
2,2 M Ω	15	35	55	
4,7 M Ω	16			

Note

Detent potentiometers (11 click, 41 click and centre-click versions), without switch, can be supplied on request.



14 mm CARBON PRESET POTENTIOMETERS

QUICK REFERENCE DATA

Resistance range (E3-series), linear law	47 Ω – 4,7 M Ω	←
Maximum dissipation at 40 °C	0,2 W	
Climatic category, IEC 68	25/070/21	
Basic specification	DIN44150	

APPLICATION

These potentiometers have been designed for preset resistance control with provision for re-adjustments. They are particularly suitable for use in radio and television receivers.

DESCRIPTION

These preset potentiometers comprise a carbon track, which is riveted on to a base plate of resin-bonded paper. They are provided with snap-in printed-wiring pins, which hold them firmly in place on the board before soldering. They are also available with straight printed-wiring pins.

The pins S1 and S3 (see Figs. 1a, 2a, 3 and 4) are connected to the ends of the carbon track; pin S2 is connected to the slider. The slider has a central screwdriver slot, a plastic knob or a wheel for adjustment. This potentiometer series includes two types: one for vertical and one for horizontal mounting on printed-wiring boards.



Outlines

Dimensions in mm

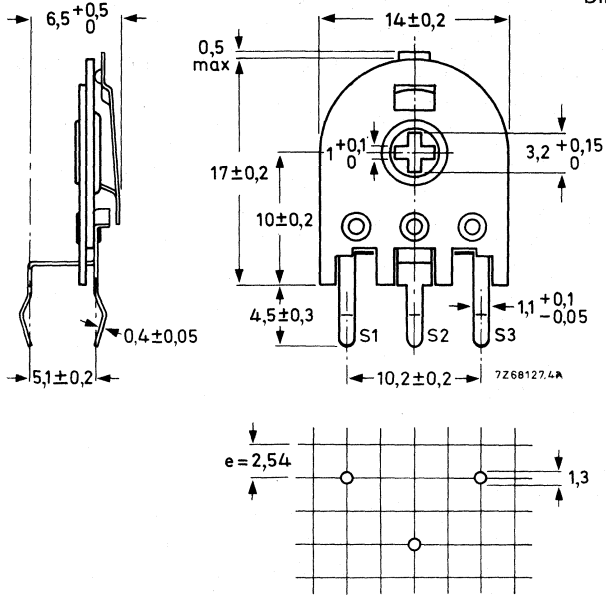

Fig.1a Potentiometer for vertical mounting, with snap-in printed-wiring pins, 2322 409 072..

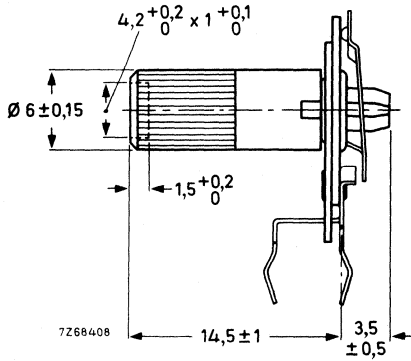

Fig.1b Potentiometer with knob at the side of the base plate, 2322 409 172..

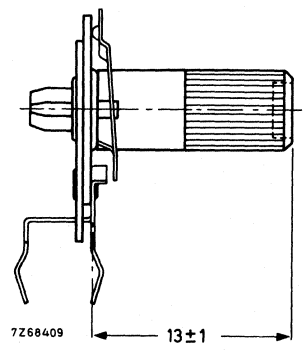

Fig.1c Potentiometer with knob at the side of the carbon track, 2322 409 272..

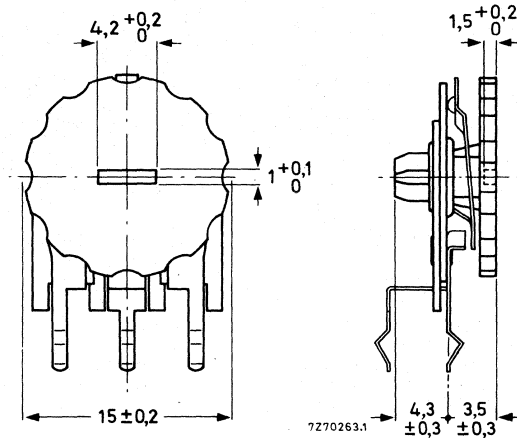

Fig.1d Potentiometer with adjustment wheel at the side of the carbon track, 2322 409 472..

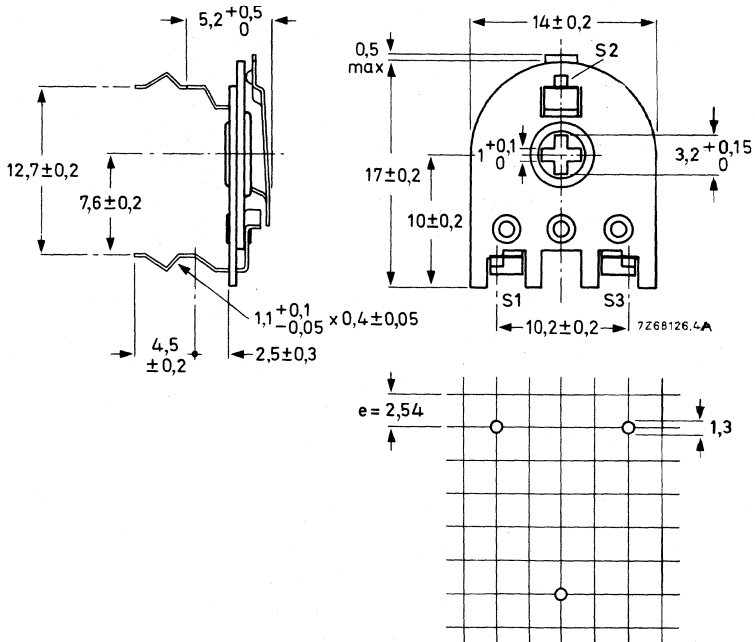

Fig.2a Potentiometer for horizontal mounting, with snap-in printed-wiring pins, 2322 409 083..

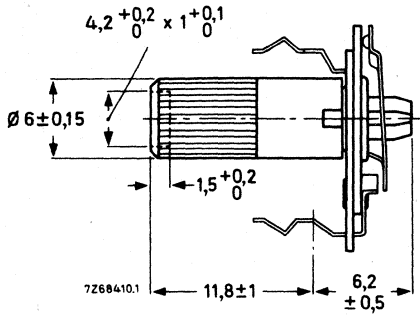

Fig.2b Potentiometer with knob at the side of the base plate, 2322 409 183..

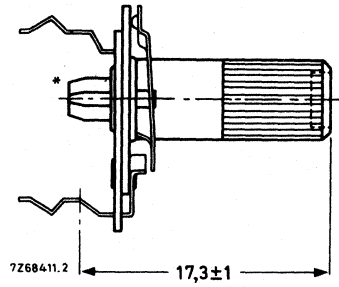

Fig.2c Potentiometer with knob at the side of the carbon track, 2322 409 283..

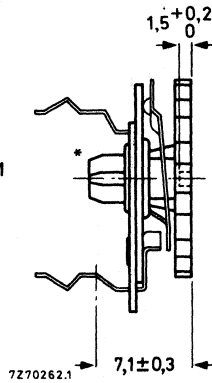
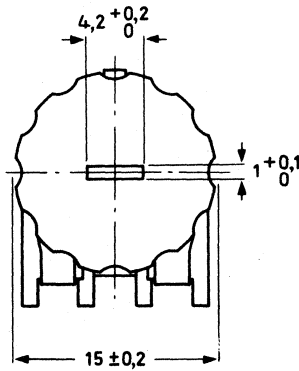

Fig.2d Potentiometer with adjustment wheel at the side of the carbon track, 2322 409 483..

* Required hole in printed-wiring board: $\varnothing 4 + 0,2$ mm.

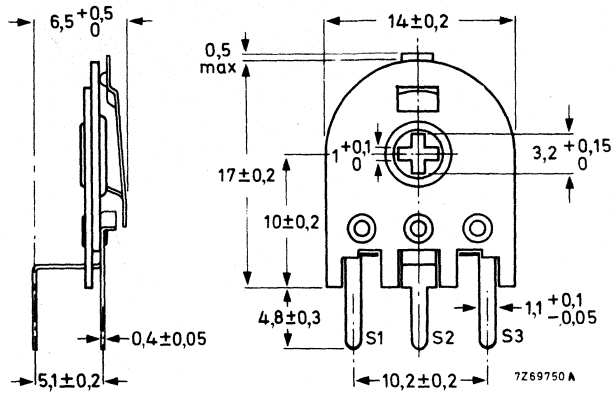

Fig.3 Potentiometer for vertical mounting, with straight printed-wiring pins, 2322 409 052..

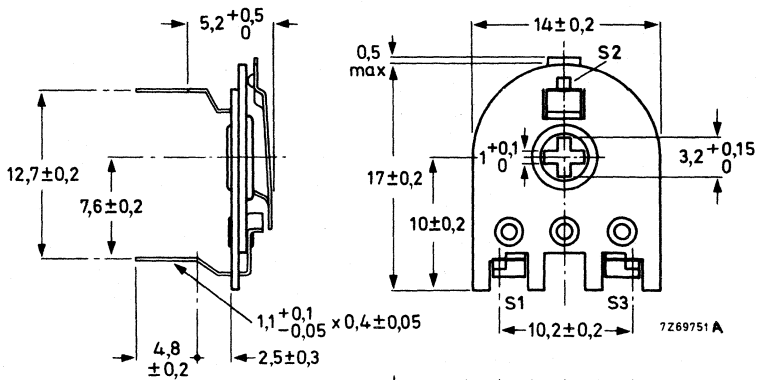
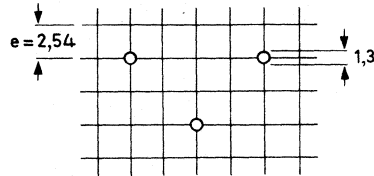
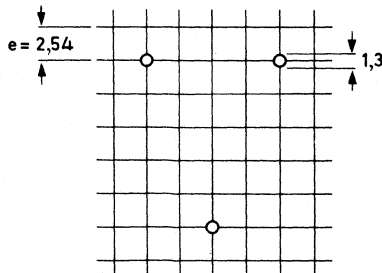

Fig.4 Potentiometer for horizontal mounting, with straight printed-wiring pins, 2322 409 063..



Note

For dimensions of knob or wheel versions see relevant drawing of snap-in-pin counterpart.

TECHNICAL DATA

Unless otherwise specified all electrical values apply at an ambient temperature of 15 to 35 °C, an atmospheric pressure of 86 to 106 kN/m² and a relative humidity of 45 to 75%.

nom resistance R_n	max voltage V		max terminal resistance Ω	limiting slider current mA		code in catalogue number
	at 40 °C	at 70 °C		at 40 °C	at 70 °C	
47 Ω	3	2,2	10	65	46	91
100 Ω	4,5	3,2	10	45	32	51
220 Ω	6,7	4,7	10	30	21,3	52
330 Ω	8	5,7	10	24,5	17,4	69
470 Ω	9,7	6,8	10	20,6	14,6	53
1 k Ω	14,2	10	25	14,1	10	54
2,2 k Ω	21	14,8	25	9,5	6,7	55
4,7 k Ω	31	21,6	100	6,5	4,6	56
10 k Ω	45	31,6	200	4,5	3,2	57
22 k Ω	67	47	400	3	2,1	58
47 k Ω	97	68	1000	2	1,4	59
100 k Ω	142	100	2000	1,4	1	61
220 k Ω	210	148	4000	0,9	0,6	62
470 k Ω	310	216	10000	0,6	0,4	63
1 M Ω	450	316	20000	0,4	0,3	64
2,2 M Ω	500	470	40000	0,3	0,2	65
4,7 M Ω	500	500	100000	0,2	0,14	66

Tolerance on the nominal resistance

±20%

Resistance law

linear

Maximum dissipation (P_{max}), at 40 °C
at 70 °C

0,2 W

0,1 W

Maximum voltage

 $\sqrt{P_{max} \cdot R_n}$; maximum 500 V
(see table above)

Working temperature range

-25 to +70 °C

Climatic category, IEC 68

25/070/21

Operating torque

3,5 to 25 mNm

Maximum end stop torque

100 mNm

Effective angle of rotation

220 ± 10°

Mechanical angle of rotation

230 ± 5°

Life

50 cycles

Mass

potentiometer without knob

0,72 g

potentiometer with knob

1,18 g

Temperature coefficient

-500 to +300 ppm/°C

MARKING

The potentiometers are marked with the nominal resistance in ink on the base plate or with embossed print on the slider.

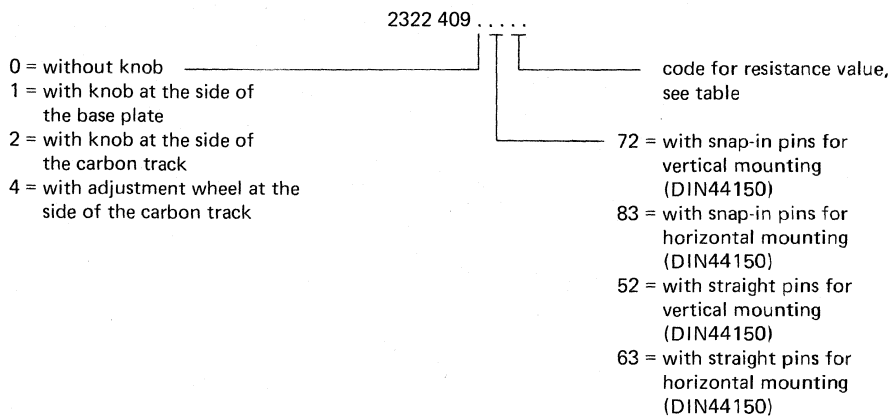
COMPOSITION OF THE CATALOGUE NUMBER

10 mm CARBON PRESET POTENTIOMETERS

QUICK REFERENCE DATA

Resistance range (E3-series), linear law	47 Ω – 4,7 M Ω
Maximum dissipation at 40 °C	0,1 W
Climatic category, IEC 68	25/070/21

APPLICATION

These potentiometers have been designed for preset resistance control with provision for re-adjustment. They are particularly suitable for use in radio and television receivers.

DESCRIPTION

These potentiometers have a resistance element of a special carbon composition with a low temperature coefficient. The element is riveted to a base plate of resin bonded paper.

The potentiometers are provided with printing-wiring pins; pins a and c (see Figs 1, 3 and 5) are connected to the ends of the carbon track, pin b is connected to the slider. The slider, which is provided with a double contact, has a screwdriver slot or a plastic knob for adjustment.

This potentiometer series includes types for vertical and for horizontal mounting on printed-wiring boards.

Note: The potentiometers are supplied with the slider at 50% of the angle of rotation.

COMPOSITION OF THE CATALOGUE NUMBER

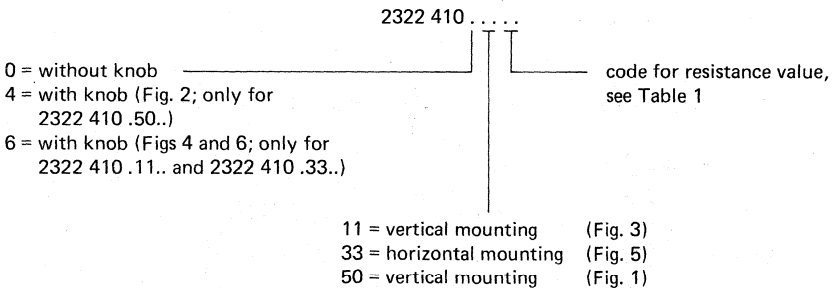

Note: catalogue number of knob (Fig. 2): 4322 047 00190 (only for 2322 410 .50..);
catalogue number of knob (Figs 4 and 6): 4322 047 27740 (only for 2322 410 .11.. and 2322 410 .33..).

MARKING

The potentiometers are marked with the nominal resistance value punched on the slider or knob.

OUTLINES

Dimensions in mm

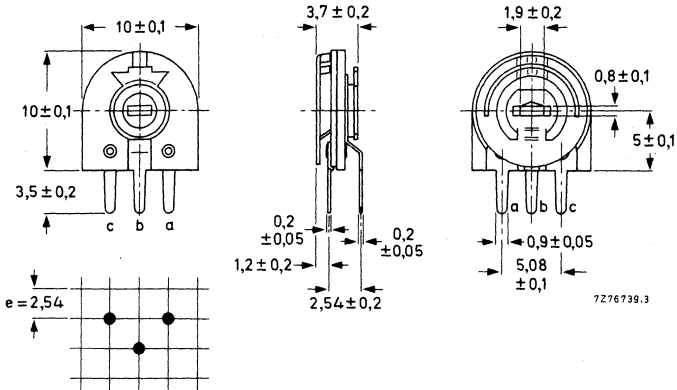

Fig.1 Potentiometer for vertical mounting 2322 410 050 ..

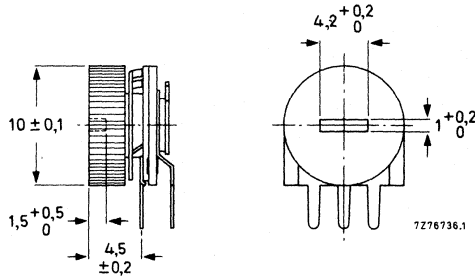

Fig.2 Potentiometer for vertical mounting with knob 2322 410 450 ..

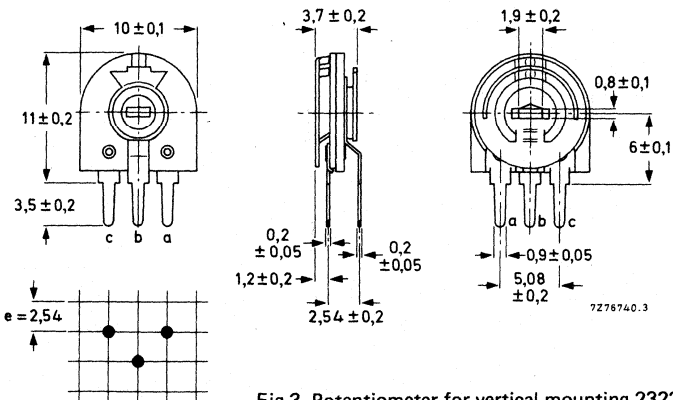

Fig.3 Potentiometer for vertical mounting 2322 410 011 ..

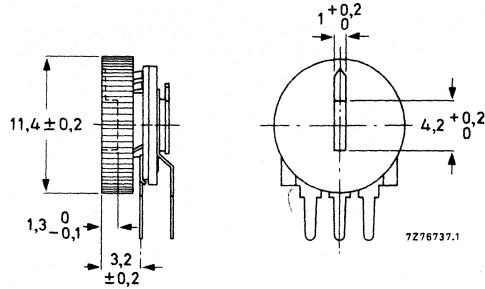

Fig.4 Potentiometer for vertical mounting with knob 2322 410 611 . .

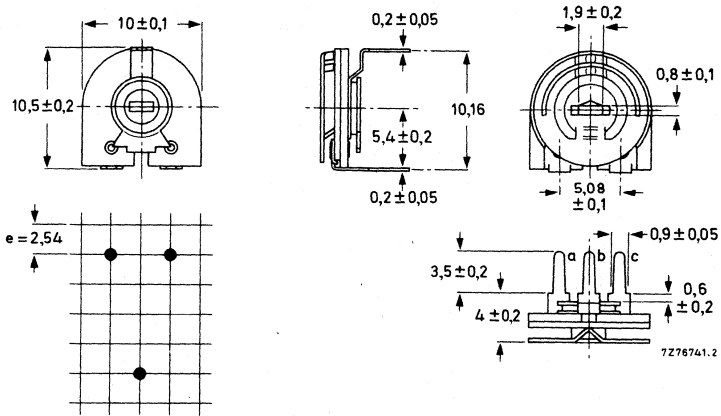

Fig.5 Potentiometer for horizontal mounting 2322 410 033 . .

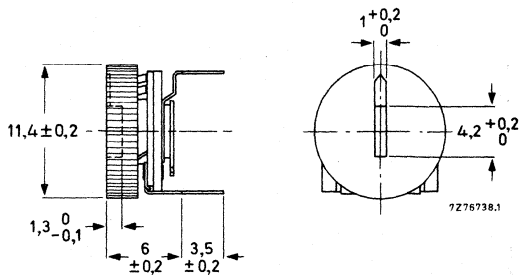

Fig.6 Potentiometer for horizontal mounting with knob 2322 410 633 . .

TECHNICAL DATA

Unless otherwise specified all electrical values apply at an ambient temperature of 15 to 35 °C, an atmospheric pressure of 86 to 106 kN/m² and a relative humidity of 45 to 75%.

→ Table 1

nom resistance	max voltage (V) at 40 °C	max terminal resistance	limiting slider current (mA) at 40 °C	code in catalogue number
R _n		Ω		
47 Ω	2,2	10	46	91
100 Ω	3,2	10	32	51
220 Ω	4,7	10	21	52
330 Ω	5,7	10	17	69
470 Ω	6,9	10	15	53
1 kΩ	10	20	10	54
2,2 kΩ	14,8	40	6,7	55
4,7 kΩ	21,7	100	4,6	56
10 kΩ	32	200	3,2	57
22 kΩ	47	400	2,1	58
47 kΩ	69	1 000	1,5	59
100 kΩ	100	2 000	1,0	61
220 kΩ	148	4 000	0,7	62
470 kΩ	150	10 000	0,32	63
1 MΩ	150	20 000	0,15	64
2,2 MΩ	150	40 000	0,068	65
4,7 MΩ	150	100 000	0,032	66

Tolerance on the nominal resistance

± 20%

Resistance law

linear

Maximum dissipation (P_{max}), at 40 °C
at 70 °C

0,1 W

0,05 W

→ Maximum voltage

 $\sqrt{P_{\max} R_n}$; maximum 150 V
(see table above)

Ambient temperature range

-25 to + 70 °C

Climatic category, IEC 68

25/070/21

Temperature coefficient

-500 to + 300 ppm/°C

→ Operating torque

3,5 to 25 mNm

Maximum end stop torque

50 mNm

Effective angle of rotation

200 ± 10°

Mechanical angle of rotation

260 ± 5°

Life

50 cycles

Mass

potentiometer without knob

0,40 g

potentiometer with knob

0,60 g

TESTS AND REQUIREMENTS

IEC 393-1 clause	IEC 68-2 test method	name of test	procedure (quick reference)	requirements
6.22.3	Ta	Soldering	Solder bath: 230 ± 10 °C, 2 ± 0.5 s.	Good tinning.
6.22.4	Tb (method 1B)	Resistance to soldering heat	Solder bath: 350 ± 10 °C, 3.5 ± 0.5 s.	$\Delta R_{ac}/R_{ac} \leq 0.5\%$.
6.24	Fc	Vibration	10 to 500 Hz, 0.75 mm or 10 g (whichever is the less), 3 directions, 2 h per direction.	$\Delta R_{ac}/R_{ac} \leq 2\%$; $\Delta V_{ab}/V_{ac} \leq 0.3\%$.
6.25	Eb	Bumping	40 g, 4000 bumps.	$\Delta R_{ac}/R_{ac} \leq 2\%$.
6.13	—	Temperature characteristic of resistance	Temperature cycle: +20 °C, -25 °C, +20 °C, +70 °C, +20 °C.	Temperature coefficient shall meet the given requirements.
6.26.2	Ba	Dry heat	16 h at +70 ± 2 °C.	
6.26.3	Db	Damp heat, cyclic	1 cycle of 24 h, 55 ± 2 °C, R.H. 95 to 100%.	
6.26.4	Aa	Cold	2 h at -55 ± 3 °C.	
6.26.6	Db	Damp heat, cyclic	5 cycles of 24 h, 55 ± 2 °C, R.H. 95 to 100%.	
			Final measurement.	$\Delta R_{ac}/R_{ac} \leq 5\%$; starting torque ≤ 30 mNm.

Climate sequence



IEC 393-1 clause	IEC 68-2 test method	name of test	procedure (quick reference)	requirements
6.30		Electrical endurance	1000 h at 70 °C, cyclic (1,5 h on, 0,5 h off; slider at 0,67 a - c). Load between a and c (0,05 W) 1000 h at 70 °C, cyclic (1,5 h on, 0,5 h off; slider at 0,67 a - c). Load between a and b (0,033 W).	$\Delta R_{ac}/R_{ac} = 5$ to 10% $\Delta V_{ab}/V_{ac} \leq 0,5\%$ $\Delta R_{ab}/R_{ab} = 5$ to 10% CRV $\leq 2\%$ of R_{total}
6.29		Mechanical endurance	50 cycles, 4 cycles/min., no load.	$\Delta R_{ac}/R_{ac} \leq 5\%$ for $R_n \leq 100$ k Ω , $\leq 10\%$ for $R_n > 100$ k Ω ; CRV $\leq 0,5\%$ of R_{total} .
6.27	Ca	Damp heat, steady state	Slider at 0,67 a - c, load between a and c; recovery 24 h, 22 \pm 1 °C, R.H. 50 \pm 5%.	CRV $\leq 0,5\%$ of R_{total} . $\Delta R_{ac}/R_{ac} \leq 5\%$; $\Delta R_{ab}/R_{ab} \leq 5\%$; $\Delta V_{ab}/V_{ac} \leq 0,2\%$.

18 mm CARBON PRESET POTENTIOMETERS

QUICK REFERENCE DATA

Resistance range (E3-series), linear law	100 Ω - 4,7 M Ω
Maximum dissipation at 25 °C	0,25 W

APPLICATION

These potentiometers have been designed for preset resistance control with provision for re-adjustments. They are particularly suitable for use in radio and television receivers.

DESCRIPTION

These preset potentiometers comprise a carbon track, which is riveted on to a base plate of resin-bonded paper. They are provided with tin-plated brass solder tags or printed-wiring pins. The tags or pins S1 and S3 (see figures on following pages) are connected to the ends of the carbon track; S2 is connected to the slider. The slider has a central screwdriver slot, a plastic knob or a wheel for adjustment.

This potentiometer series includes seven types:

- Potentiometers 2322 411 .00.. provided with solder tags, which are perpendicular on the base plate. They are suited for direct mounting in the wiring; if necessary they can be fitted with a screw in the mounting hole (Fig.1).
- Potentiometers 2322 411 .22.. provided with pins, for vertical mounting on printed-wiring boards (Fig.2).
- Potentiometers 2322 411 .72.. * provided with pins, for vertical mounting on printed-wiring boards according to DIN 44150 (Fig.3).
- Potentiometers 2322 411 .73.. provided with pins, for vertical mounting on printed-wiring boards (Fig.4).
- Potentiometers 2322 411 .33.. provided with pins, for horizontal mounting on printed-wiring boards (Fig.5).
- Potentiometers 2322 411 .83.. * provided with pins, for horizontal mounting on printed-wiring boards according to DIN 44150 (Fig.6).
- Potentiometers 2322 411 .84.. provided with pins, for horizontal mounting on printed-wiring boards according to DIN 44151 (Fig.7).

* Preferred type.

Outlines

Dimensions in mm

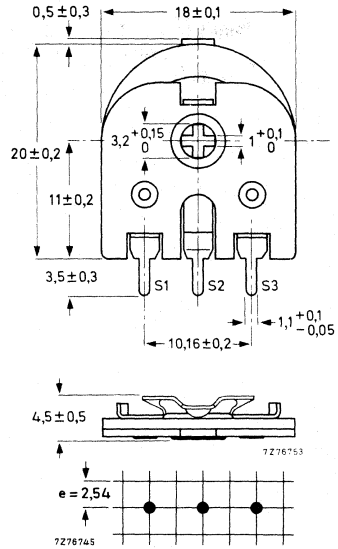
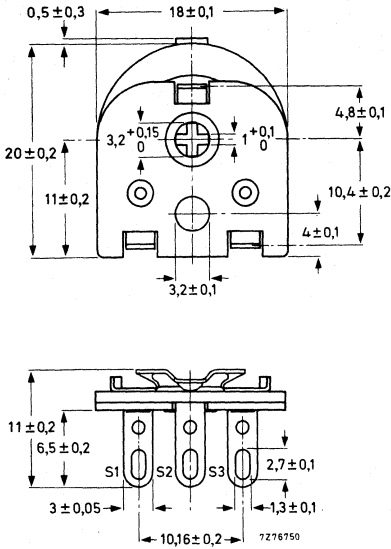

Fig.1 Potentiometer 2322 411 000..

Fig.2 Potentiometer 2322 411 022..

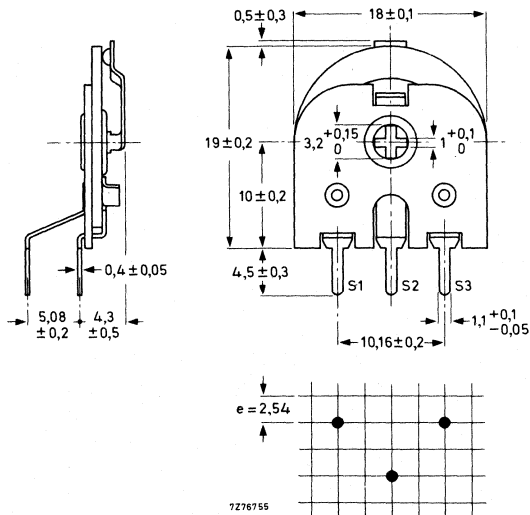

Fig.3 Potentiometer 2322 411 072..

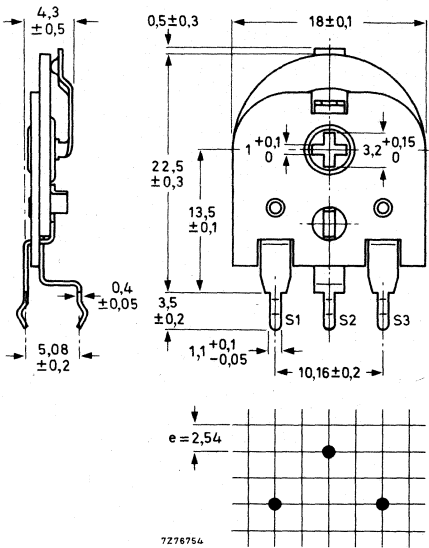

Fig.4 Potentiometer 2322 411 073..

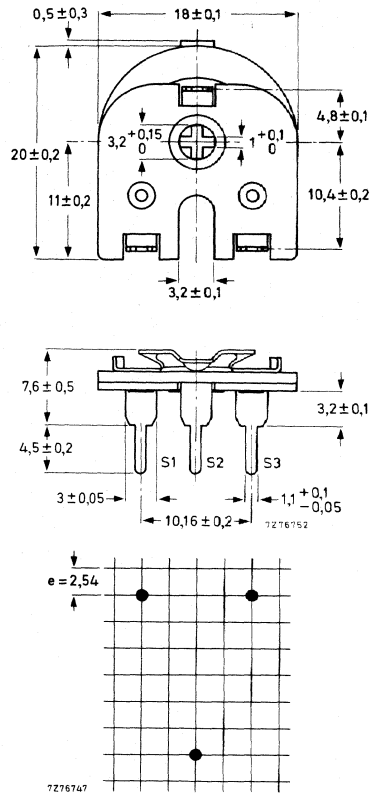

Fig.5 Potentiometer 2322 411 033..

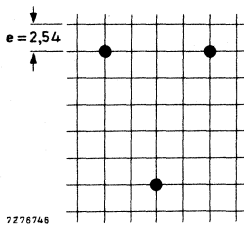
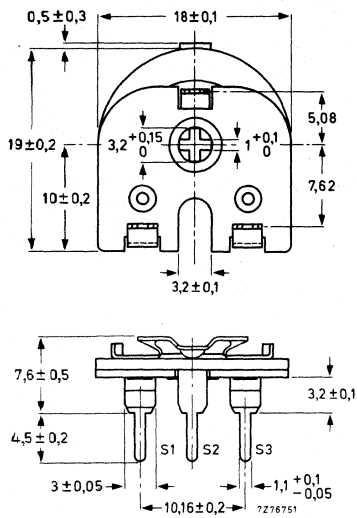

Fig.6 Potentiometer 2322 411 083..

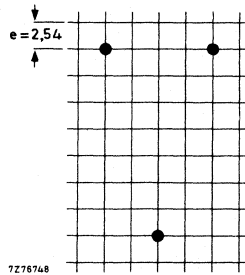
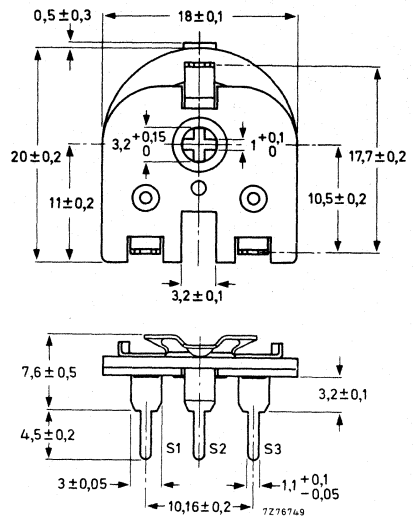

Fig.7 Potentiometer 2322 411 084..

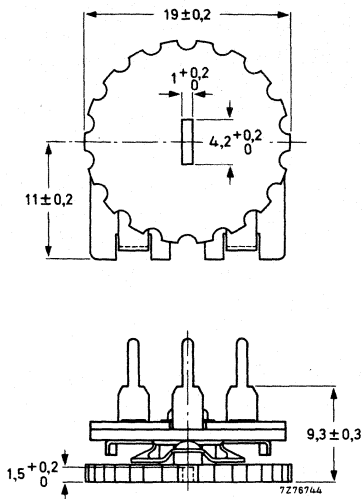

Fig.8 Potentiometer 2322 411 433..
(adjustment wheel at the side of
the carbon track).

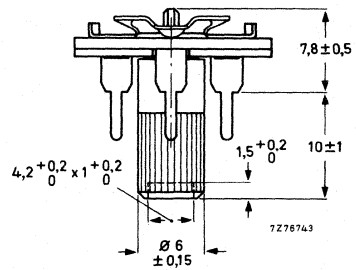

Fig.9 Potentiometer 2322 411 133..
(adjustment knob * at the side of
the base plate).

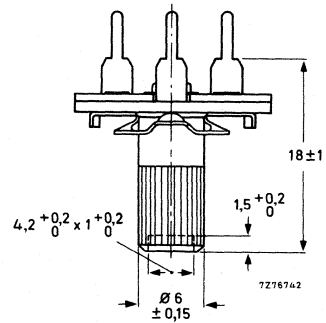

Fig.10 Potentiometer 2322 411 233..
(adjustment knob * at the side of
the carbon track).

* Potentiometers with temperature-resistant knobs (up to 230 °C) are supplied on request.

TECHNICAL DATA

nom resistance R_n	max terminal resistance Ω	V_{max} (d.c. or r.m.s.) at $T_{amb} = 40\text{ }^\circ\text{C}$ V	limiting slider current mA	code in catalogue number
100 Ω	10	5	32	51
220 Ω	10	7	22	52
330 Ω	10	9	18	69
470 Ω	10	11	14	53
1 k Ω	25	16	10	54
2,2 k Ω	25	22	7	55
4,7 k Ω	100	35	4,5	56
10 k Ω	200	50	3,2	57
22 k Ω	400	70	2,2	58
47 k Ω	1 000	110	1,4	59
100 k Ω	2 000	160	1,0	61
220 k Ω	4 000	220	0,7	62
470 k Ω	10 000	370	0,45	63
1 M Ω	20 000	500	0,32	64
2,2 M Ω	40 000	500	0,22	65
4,7 M Ω	100 000	500	0,14	66

Tolerance on the nominal resistance	$\pm 20\%$
Resistance law	linear
Maximum dissipation at 25 $^\circ\text{C}$ at 70 $^\circ\text{C}$	0,25 W 0,15 W
Limiting voltage	500 V (d.c.) 500 V (r.m.s.)
Ambient temperature range	-25 to $+70\text{ }^\circ\text{C}$
Resistance change after humidity test (21 days, $T_{amb} = 40\text{ }^\circ\text{C}$, R.H. = 90 - 95%) after recovery of 1 h * after recovery of 24 h *	$< 20\%$ $< 10\%$
Operating torque	5 to 50 mNm
Maximum end stop torque	100 mNm
Effective angle of rotation	$200 \pm 10^\circ$
Mechanical angle of rotation	215–225 $^\circ$
Temperature coefficient	-500 to $+300$ ppm/ $^\circ\text{C}$

* Preconditioning (min 48 h) and recovery at $23 \pm 1\text{ }^\circ\text{C}$, R.H. = $50 \pm 2\%$.

MARKING

Nominal resistance and production code in ink on the base plate.

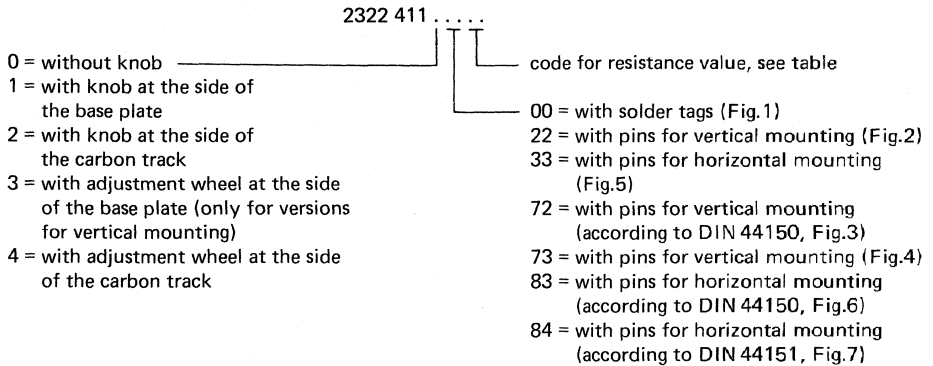
COMPOSITION OF THE CATALOGUE NUMBER

Catalogue number of adjustment wheel: 4322 047 08230

Catalogue number of adjustment knob : 4322 047 08280.

MULTITURN CARBON PRESET POTENTIOMETERS

QUICK REFERENCE DATA

Nominal resistance values	
linear resistance law	100 Ω - 4,7 M Ω
logarithmic resistance law	1 k Ω - 2,2 M Ω
special resistance law	100 k Ω
Maximum dissipation at 40 °C	see Fig.3
Number of turns of spindle	
potentiometers 2322 412	20
potentiometers 2322 413	10
potentiometers 2322 414	40
Climatic category (IEC 68)	25/070/21

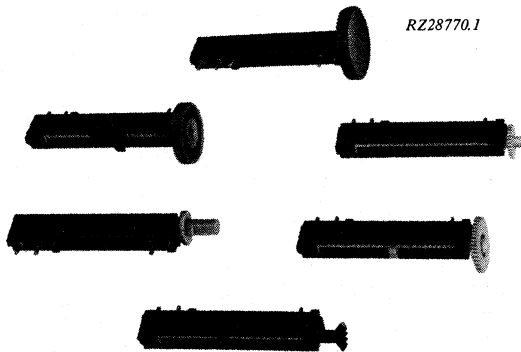

APPLICATION

The potentiometers have been designed for preset resistance adjustment in capacitance diode television tuners. However they can also be applied for capacitance diode tuning of other apparatus, e.g. radio receivers, or for any other fine resistance adjustment.

DESCRIPTION

A straight carbon track is fitted on to a base plate of resin-bonded paper, which is mounted in a housing of black synthetic resin. The terminals are suited for mounting on printed-wiring boards. The slider is activated by a silvered threaded spindle. No damage occurs when one continues to turn the spindle after the slider has reached an extreme position. The potentiometers can be delivered with various adjustment provisions and with or without a scale indicator.

All versions are available with linear or logarithmic resistance law; the 100 k Ω versions are also available with special resistance law.

2322 412
 2322 413
 2322 414

CMP20
 CMP10
 CMP40

Dimensions of the housing (mm)

The housing has been drawn without scale indicator and adjustment provision; these parts are given in the paragraphs below.

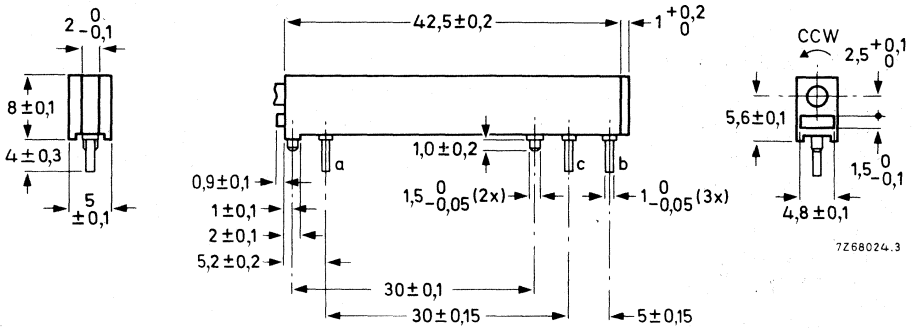
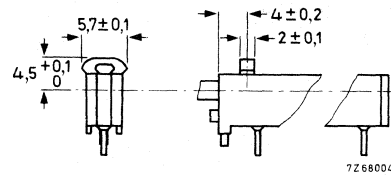
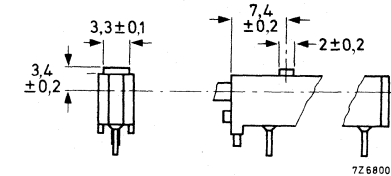
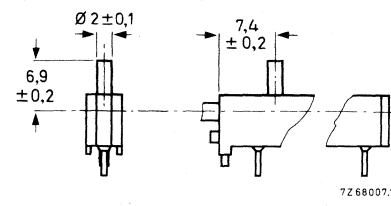
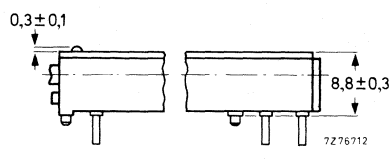

Fig. 1 Terminals a and c are connected to the ends of the carbon track; terminal b is connected to the slider contact.

Indicators

type (dimensions in mm)	colour	code in catalogue number 2322 41.
	red	1
	red	2

type (dimensions in mm)	colour	code in catalogue number 2322 41
 <p>7268004.1</p>	red	<p>↓</p> <p>3</p>
 <p>7268005.1</p>	yellow	4
 <p>7268007.1</p>	red	5
without indicator		0
<p>without indicator, with black dust cover on the housing.</p>  <p>7276712</p>		8



2322 412
 2322 413
 2322 414

CMP20
 CMP10
 CMP40

Adjustment provisions

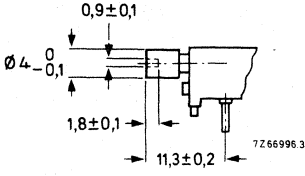
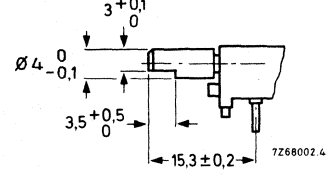
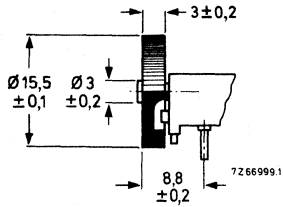
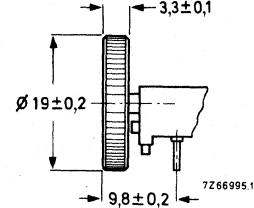
type (dimensions in mm)	colour	code in catalogue number 2322 41 ↓
	grey	51
	grey	52
	red	Knob: approx. 60 notches 61
	black	Knob: approx. 48 notches 62

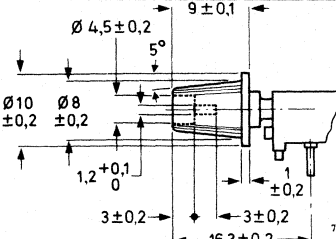
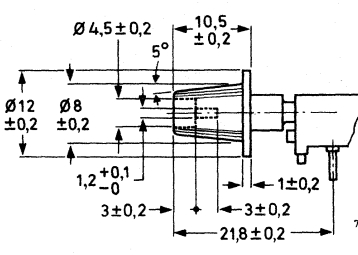
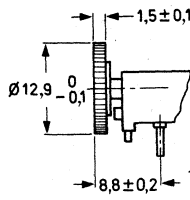
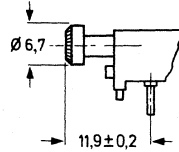
type (dimensions in mm)	colour	code in catalogue number 2322 41
 <p>7268001.3</p>	black	<p>↓</p> <p>63 ←</p>
 <p>7268000.2</p>	black	64
 <p>7266997.1</p> <p>Gearwheel: module = 0,5 number of teeth = 24 tooth height = 1,2</p>	white	82
 <p>7266994.3</p> <p>Gearwheel: module = 0,5 number of teeth = 12 shape according to DIN867</p>	black	83 ←



2322 412
2322 413
2322 414

CMP20
CMP10
CMP40

TECHNICAL DATA

Unless stated otherwise, all electrical values have been determined at an ambient temperature of 15 to 35 °C, an air pressure of 860 to 1060 mbar and a relative humidity of 45 to 75%.

nom. resistance (R_n)	resist. law	max. voltage (V d.c. or V a.c.)			max. terminal resistance	max. attenuation (dB)	limiting slider current (mA)		
		$T_{amb} = 40\text{ °C}$		$T_{amb} = 70\text{ °C}$					
		$\Delta R < 20\%$ (note 1)	$\Delta R < 10\%$ (note 1)	$\Delta R < 20\%$ (note 1)					
100 Ω	linear	5,5	5,0	3,9	10 Ω	20	55		
220 Ω		8,1	7,4	5,7	20 Ω	20	37		
470 Ω		11,8	10,8	8,4	35 Ω	30	25		
1 k Ω		17	15,8	12,2	50 Ω	30	17		
2,2 k Ω		26	23	18	100 Ω	40	11		
4,7 k Ω		37	34	24	200 Ω	40	8		
10 k Ω		53	47	37	300 Ω	40	5,3		
22 k Ω		76	66	54	600 Ω	50	3,5		
47 k Ω		108	91	76	1 k Ω	50	2,3		
100 k Ω		152	122	107	2 k Ω	50	1,5		
220 k Ω		217	166	153	3,5 k Ω	60	0,99		
470 k Ω		306	216	216	6 k Ω	60	0,65		
1 M Ω		425	274	300	10 k Ω	70	0,43		
2,2 M Ω		600	330	420	20 k Ω	70	0,27		
4,7 M Ω		840 (2)	340	590	50 k Ω	70	0,18		
1 k Ω		logarithmic	10	8,9	7,1	10 Ω	(5)	10	(3)
2,2 k Ω			14	12,8	10,2	20 Ω		50	
4,7 k Ω	20		17,5	14,5	35 Ω	50		4,4	
10 k Ω	29		24	20	50 Ω	50		2,9	
22 k Ω	42		34	29	100 Ω	60		1,9	
47 k Ω	59		47	41	200 Ω	60		1,3	
100 k Ω	85		63	60	250 Ω	60		0,85	
220 k Ω	122		87	86	500 Ω	70		0,55	
470 k Ω	172		112	120	1 k Ω	70		0,37	
1 M Ω	240		141	170	2 k Ω	80		0,24	
2,2 M Ω	350	182	244	5 k Ω	80	0,16			
100 k Ω	special	85	63	60	500 Ω	60	0,85 (4)		

Notes

1. Measured after 1000 h.
2. Max. 600 V (a.c.).
3. Slider contact between 20 and 100% of R_{tot} . For slider contact positions between 0 and 20% of R_{tot} the values have to be multiplied by 6.
4. Slider contact between 20 and 100% of R_{tot} . For slider contact positions between 0 and 20% of R_{tot} the value has to be multiplied by 2,4.
5. Measured between terminals a and b.

Tolerance on nominal resistance	± 20%
Resistance law and tolerance	see Fig. 2
Maximum permissible dissipation (P_{\max})	see Fig. 3
Contact resistance between carbon track and slider contact, the slider being moved 1 mm/s (see also "Measurement of the contact resistance")	
linear resistance law	≤ 3% of R_{total}
logarithmic resistance law,	
for 0- 40% of effective travel	≤ 0, 75% of R_{total}
for 40- 70% of effective travel	≤ 2% of R_{total}
for 70- 100% of effective travel	≤ 8% of R_{total}
special resistance law,	
for 0- 40% of effective travel	≤ 1, 2% of R_{total}
for 40- 60% of effective travel	≤ 3% of R_{total}
for 60- 100% of effective travel	≤ 6% of R_{total}
Crackle voltage at maximum slider current of 1 mA, the slider being moved maximum 0, 025 mm/s,	
$R_n = 100 \text{ k}\Omega$, linear law	≤ 100 mV
$R_n = 100 \text{ k}\Omega$, special law,	
for 0- 60% of effective travel	≤ 100 mV
for 60- 100% of effective travel	≤ 150 mV
Resistance change with temperature and humidity	see Figs. 4 and 5
Change of preset voltage with temperature and humidity	see Figs. 6 and 7
Change of preset voltage after vibration test (I. E. C. 68, test Fc) and shock test (I. E. C. 68, test Ea)	≤ 0, 1% of total voltage typ. 0, 05% of total voltage
Operating temperature range	-25 to + 70 °C
Climatic category (I. E. C. 68)	25/070/21
Operating torque	1, 5 - 10 mNm
Mechanical number of turns of spindle	
potentiometers 2322 412	$19 \pm \frac{1}{2}$
potentiometers 2322 413	$9\frac{1}{2} \pm \frac{1}{2}$
potentiometers 2322 414	38 ± 1
Maximum axial run-out including radial play of spindle	0, 15 mm
Maximum permissible axial spindle load (push and pull)	≤ 2, 5 N

2322 412
 2322 413
 2322 414

CMP20
 CMP10
 CMP40

Mechanical travel of slider contact	25,6 ± 0,3 mm
Effective travel of slider contact	24 - 1 mm
Solderability (to IEC 68-2, test T)	230 ± 10 °C, for 2 ± 0,5 s
Thermal shock test (to IEC 68-2, test T)	350 ± 10 °C, for 2 ± 0,5 s
Life (at a rate of 20 rev/min)	50 x in both directions + 3 rotations at both ends

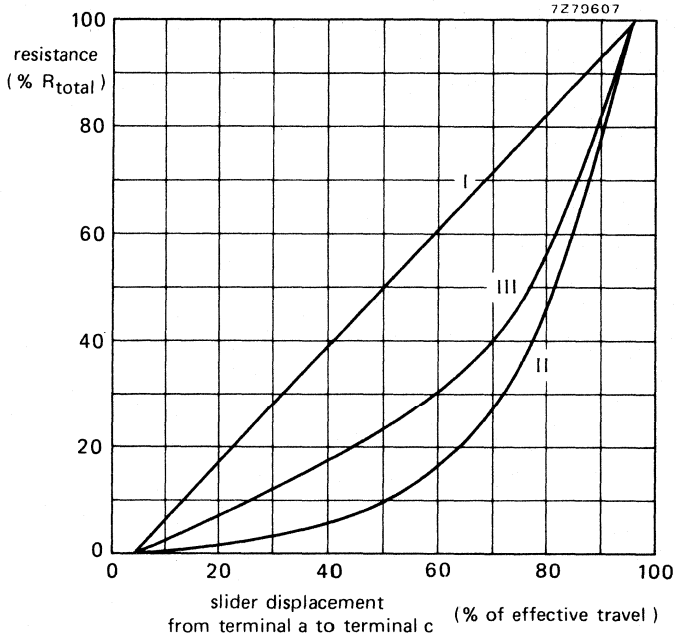

Fig. 2 Resistance as a function of slider displacement. Counter-clockwise knob rotation results in an increase of resistance between a and b (Fig. 1).

curve	resistance law	tolerance on resistance law	
		displacement (% of effective travel)	resistance (% of R _{total})
I	linear	between 36,5 and 38,5 between 61,5 and 63,5	33,5 - 41,5 58,5 - 66,5
II	logarithmic	between 36,5 and 38,5 between 61,5 and 63,5	3,5 - 8,5 12 - 26
III	special	between 36,5 and 38,5 between 61,5 and 63,5 between 86,5 and 88,5	14 - 22 28 - 38 60 - 75

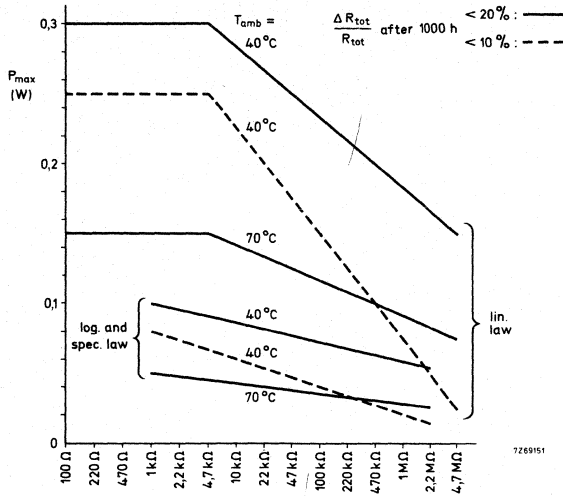

Fig. 3. Maximum permissible power dissipation

Resistance change as a function of the temperature; relative humidity 40 to 80% at 25 °C.

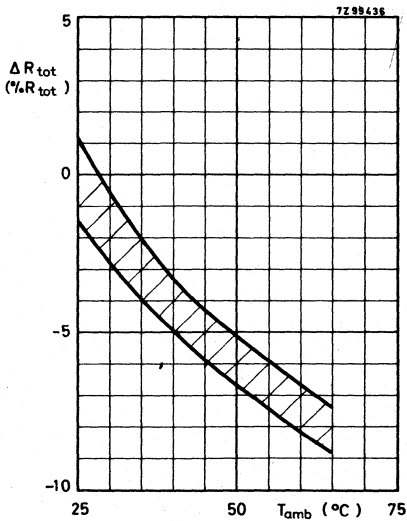

Fig. 4. $R_n = 100$ k Ω , linear law

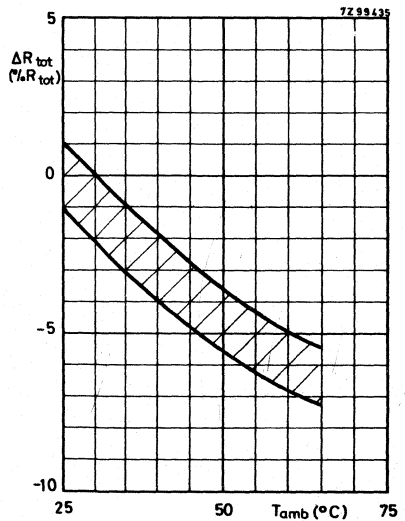

Fig. 5. $R_n = 100$ k Ω , special law

Change of preset voltage as a function of the temperature, V_{a-b} being 30% of V_{a-c} ; relative humidity 40 to 80% at 25 °C.

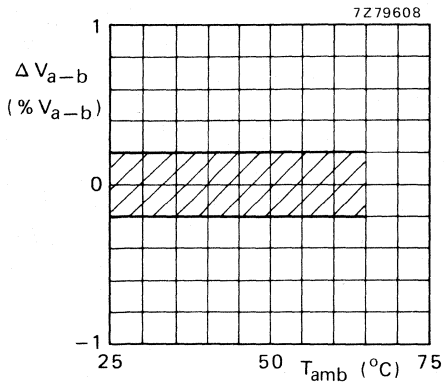

Fig. 6 $R_n = 100 \text{ k}\Omega$, linear law.

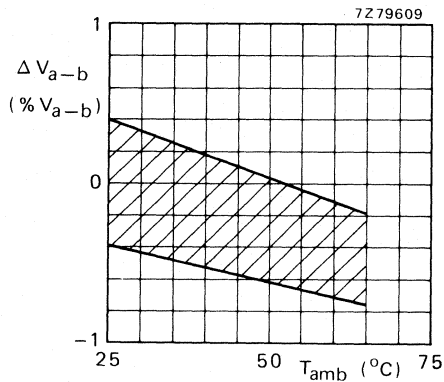
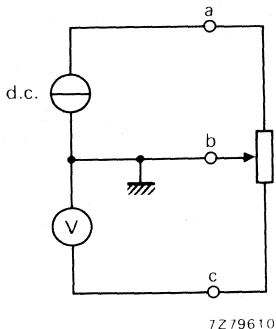

Fig. 7 $R_n = 100 \text{ k}\Omega$, special law.

Measurement of the contact resistance



7Z79610

Fig. 8.

A d.c. current source which supplies a constant direct current (I) of e.g. 1 mA, is connected to the pins a and b of the potentiometer; for the diagram of the d.c. current source, see Fig. 9. The d.c. voltage (V) resulting from the contact resistance (R_C) and the d.c. current is measured between the pins b and c ($V = I \cdot R_C$).

During the measurement the slider contact is moved with a constant speed of 1 mm/s.
 The input resistance of the d.c. voltmeter must be at least $10 \text{ M}\Omega$.

Note - Circuit diagram of the direct current source used for measuring the contact resistance. Open-circuit output voltage is 380 V.

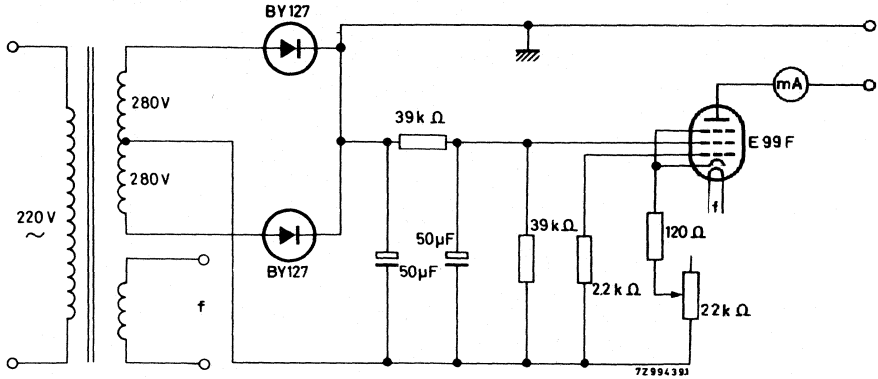

Fig. 9

MOUNTING

The terminals may be dipsoldered over a length of 2 mm max. in a solder bath of 260 °C max. for 4 s max.

When a soldering bit is used, its temperature must not exceed 360 °C for 1,5 s and neither axial nor radial stress must be exerted on the terminals.

MARKING

The potentiometers are marked with the nominal resistance value, resistance law, period and year of manufacture.

COMPOSITION OF THE CATALOGUE NUMBER

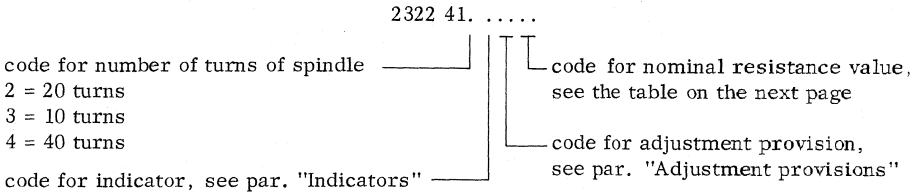

2322 412
2322 413
2322 414

MULTITURN CARBON
PRE-SET POTENTIOMETERS

nominal resistance	code in catalogue number		
	linear law	logarithmic law	special law
100 Ω	01		
220 Ω	02		
470 Ω	03		
1 k Ω	04	24	
2,2 k Ω	05	25	
4,7 k Ω	06	26	
10 k Ω	07	27	
22 k Ω	08	28	
47 k Ω	09	29	
100 k Ω	11	31	38
220 k Ω	12	32	
470 k Ω	13	33	
1 M Ω	14	34	
2,2 M Ω	15	35	
4,7 M Ω	16		

25 mm SLIDE CARBON POTENTIOMETERS

QUICK REFERENCE DATA

Nominal resistance values	
linear resistance law	1 k Ω - 4,7 M Ω
logarithmic resistance law	1 k Ω - 2,2 M Ω
Maximum dissipation at 40 °C	see graph (Fig. 3)
Climatic category, IEC 68	25/070/21

APPLICATION

These potentiometers are particularly suitable for use in radio and television receivers.

DESCRIPTION

A straight carbon track is fitted on to a base plate of resin bonded paper, which is mounted in a housing of black synthetic resin. The terminals are suited for mounting on printed-wiring boards.

The slider contact is adjusted by means of a knob, which moves along a silvered spindle. Two types of slider knob are available. The potentiometers are available with linear or logarithmic resistance law.

Outlines

Dimensions in mm

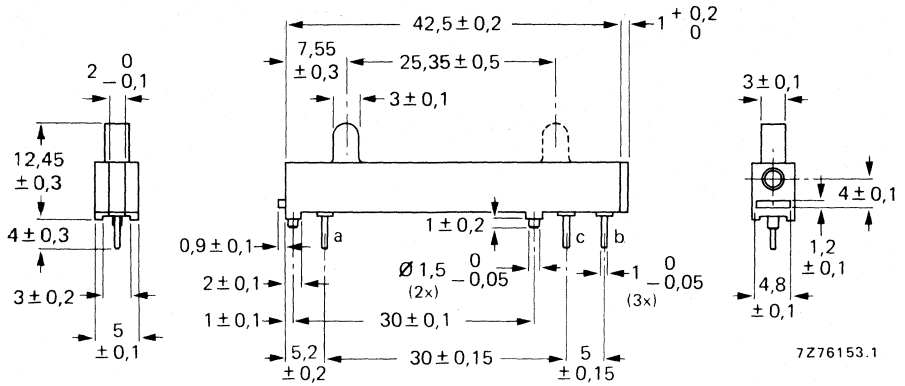

Fig. 1a Potentiometer with symmetrically placed slider.
 a and c = beginning and end terminals respectively.
 b = slider terminal.

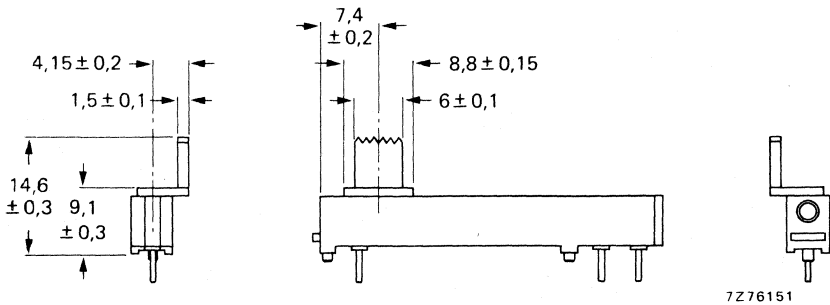

Fig. 1b Potentiometer with asymmetrically placed slider.
 Dimensions are identical with those in Fig. 1a except as shown.

TECHNICAL DATA

Unless stated otherwise, all electrical values have been determined at an ambient temperature of 15 to 35 °C, an air pressure of 860 to 1060 mbar and a relative humidity of 45 to 75%.



nom. resistance (R_n)	resist. law	max. voltage (V d.c. or V a.c.)			max. terminal resistance	max. atten- uation (dB)	limiting slider current (mA) $\Delta R < 20\%$ (1)		
		$T_{amb} = 40\text{ }^\circ\text{C}$		$T_{amb} = 70\text{ }^\circ\text{C}$			at 40 °C	at 70 °C	
		$\Delta R < 20\%$ (note 1)	$\Delta R < 10\%$ (note 1)	$\Delta R < 20\%$ (note 1)					
1 k Ω	linear	17	15,8	12,2	50 Ω	30	17	12	
2,2 k Ω		26	23	18	100 Ω	40	11	8,2	
4,7 k Ω		37	34	24	200 Ω	40	8	5,6	
10 k Ω		53	47	37	300 Ω	40	5,3	3,7	
22 k Ω		76	66	54	600 Ω	50	3,5	2,4	
47 k Ω		108	91	76	1 k Ω	50	2,3	1,6	
100 k Ω		152	122	107	2 k Ω	50	1,5	1,1	
220 k Ω		217	166	153	3,5 k Ω	60	0,99	0,70	
470 k Ω		306	216	216	6 k Ω	60	0,65	0,46	
1 M Ω		425	274	300	10 k Ω	70	0,43	0,30	
2,2 M Ω		600	330	420	20 k Ω	70	0,27	0,19	
4,7 M Ω	840 (2)	340	590	50 k Ω	70	0,18	0,13		
1 k Ω	loga- rithmic	10	8,9	7,1	10 Ω	(3)	40	10	7,0
2,2 k Ω		14	12,8	10,2	20 Ω		50	6,6	4,7
4,7 k Ω		20	17,5	14,5	35 Ω		50	4,4	3,0
10 k Ω		29	24	20	50 Ω		50	2,9	2,0
22 k Ω		42	34	29	100 Ω		60	1,9	1,3
47 k Ω		59	47	41	200 Ω		60	1,3	0,9
100 k Ω		85	63	60	250 Ω		60	0,85	0,60
220 k Ω		122	87	86	500 Ω		70	0,55	0,39
470 k Ω		172	112	120	1 k Ω		70	0,37	0,26
1 M Ω		240	141	170	2 k Ω		80	0,24	0,17
2,2 M Ω		350	182	244	5 k Ω		80	0,16	0,11



Notes

1. Measured after 1000 h.
2. Max. 600 V (a.c.).
3. Measured between terminals a and b.

Tolerance on nominal resistance	±20%
Resistance law	see Fig. 2
Maximum permissible dissipation (P_{\max})	see Fig. 3
Contact resistance between carbon track and slider contact	
linear resistance law	≤ 4% of R_{total}
logarithmic resistance law	≤ 6% of R_{total}
Operating temperature range	-25 to +70 °C
Climatic category (IEC 68)	25/070/21
Operating force (F)	1 to 2,5 N ($\frac{F_{\max}}{F_{\min}} \leq 2$)
Permissible force with slider at end stop ¹⁾	≤ 30 N
Permissible load perpendicular to the direction of movement ¹⁾	≤ 10 N
Permissible axial force on slider (push and pull) ¹⁾	≤ 20 N
Effective travel of slider contact	24 - 1 mm
Mechanical travel of slider contact	25,35 ± 0,5 mm
Life	5000 x in both directions

¹⁾ Measured for 5 s, 5 mm above centre of spindle.

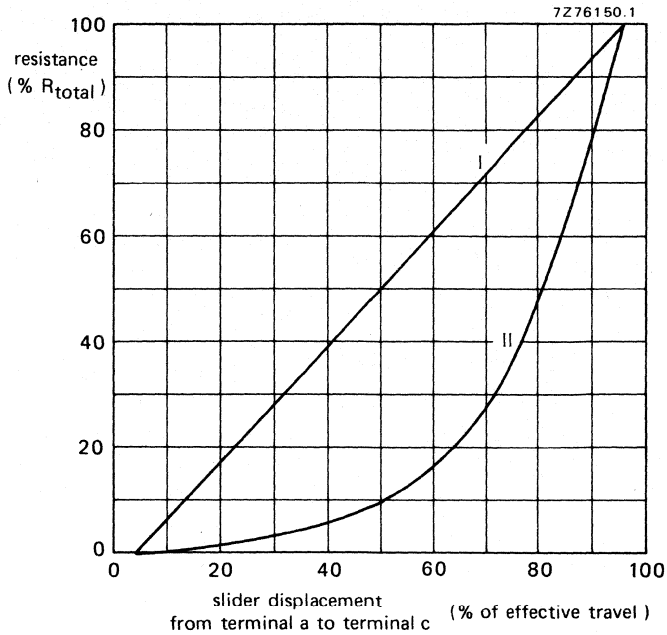
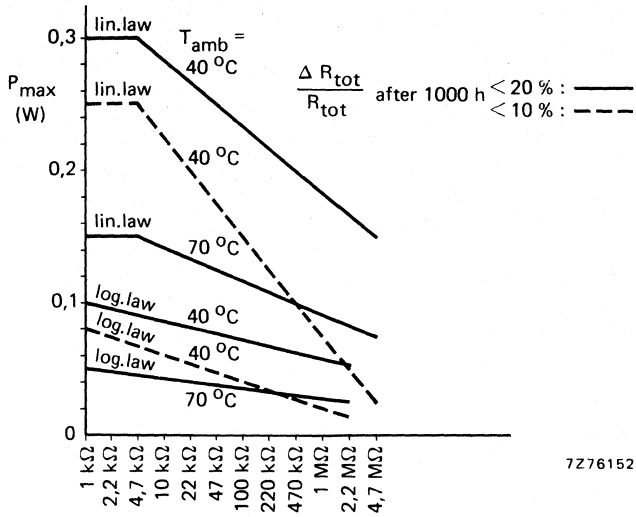

Fig. 2 Resistance as a function of slider displacement.
curve I = linear resistance law;
curve II = logarithmic resistance law.



7276152

Fig. 3. Maximum permissible power dissipation.

MOUNTING

The terminals may be dip-soldered over a length of 2 mm max. in a solder bath of 260°C max. for 4 s max.

When a soldering bit is used, its temperature must not exceed 360°C for 1,5 s and neither axial nor radial stress must be exerted on the terminals.

MARKING

The potentiometers are marked with the nominal resistance value, resistance law, period and year of manufacture.

COMPOSITION OF THE CATALOGUE NUMBER

2322 415 .00.

code for slider

1 = symmetrically placed (Fig. 1a)

2 = asymmetrically placed (Fig. 1b)

code for nominal resistance value, see the table, on the next page

nominal resistance	code in catalogue number	
	linear law	logarithmic law
1 k Ω	04	24
2,2 k Ω	05	25
4,7 k Ω	06	26
10 k Ω	07	27
22 k Ω	08	28
47 k Ω	09	29
100 k Ω	11	31
220 k Ω	12	32
470 k Ω	13	33
1 M Ω	14	34
2,2 M Ω	15	35
4,7 M Ω	16	



60 mm SLIDE CARBON POTENTIOMETERS

QUICK REFERENCE DATA

Nominal resistance values	
linear resistance law	220 Ω – 10 M Ω
logarithmic, reversed logarithmic and semi-logarithmic resistance law	1 k Ω – 4,7 M Ω
Maximum dissipation at 40 °C	
linear resistance law	0,4 W
logarithmic, reversed logarithmic and semi-logarithmic resistance law	0,2 W
Category (IEC68)	10/070/21

DESCRIPTION

This slide carbon potentiometer series includes two types:

- single potentiometers, for general purposes,
- tandem potentiometers, for stereophonic purposes.

The single potentiometers comprise a straight carbon track, which is fitted on to a base plate of resin bonded paper, mounted in a housing of black synthetic resin.

The tandem potentiometers are composed of two carbon tracks, fitted on base plates of resin bonded paper, which are situated in one housing. The base plates are placed in such a way that the tracks are opposite each other.

The terminals S_{11} and S_{13} (single) or S_{11}/S_{21} and S_{13}/S_{23} (tandem) are connected to the ends of the carbon track (see Figs 1 and 2); terminal S_{12} (single) or S_{22} (tandem) is connected to the slider contact. The potentiometers can be supplied with a tap at 1/2, 1/3 or at 1/3 and 2/3 of the total travel.

Both types are available with or without a metal screening at the outer surface of the potentiometer housing, providing general protection against external interference. The tandem potentiometers can also be supplied with a metal screening between the two carbon tracks, thus preventing crosstalk.

The potentiometers are available with different connecting terminals and adjustment provisions. ←

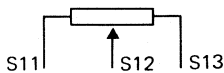

Single type

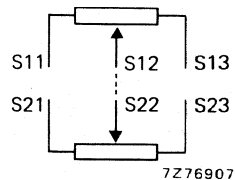

Tandem type

7276907

Types

Dimensions in mm

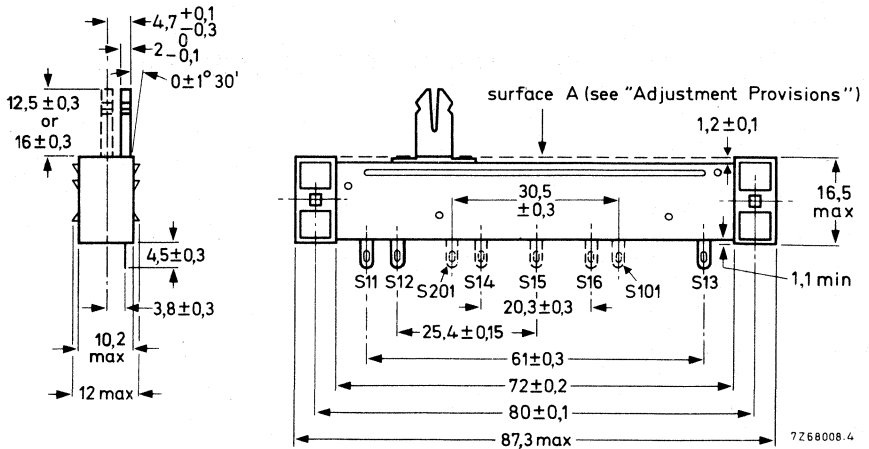

Fig. 1 Single slide potentiometer with solder tags.

- S11, S13 = beginning and end terminals respectively
- S12 = slider terminal
- S14, S15, S16 = tap terminals at 1/3, 1/2 and 2/3 of the total travel respectively
- S101, S201 = earthing terminals (connected to external screening)

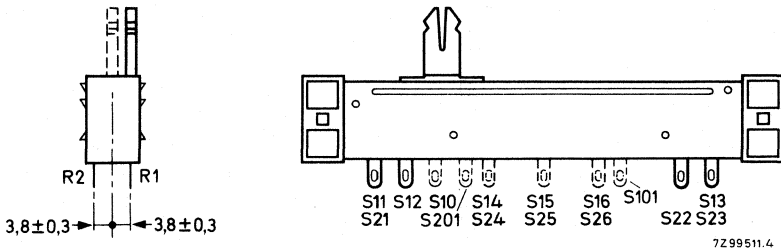

Fig. 2 Tandem slide potentiometer with solder tags.

Dimensions are identical with those in Fig. 1 except as shown.

- | | | | |
|---|------------------------|---|------------------------|
| S11, S13 = beginning and end terminals resp. | } potentiometer 1 (R1) | S21, S23 = beginning and end terminals resp. | } potentiometer 2 (R2) |
| S12 = slider terminal | | S22 = slider terminal | |
| S14, S15, S16 = tap terminals at 1/3, 1/2 and 2/3 of the total travel resp. | | S24, S25, S26 = tap terminals at 1/3, 1/2 and 2/3 of the total travel resp. | |
| S101, S201 = earthing terminals (connected to external screening) | | | |
| S10 = earthing terminal (connected to internal screening) | | | |

To determine the side on which potentiometer R1 is situated, the customer should look for the marking: this is always placed at the beginning of R1.

Connecting terminals

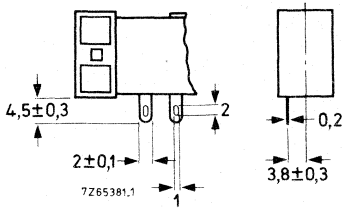

Fig. 3 Solder tags.

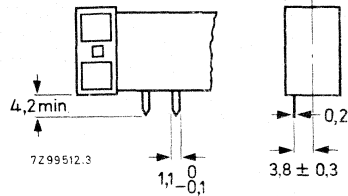

Fig. 4 Printed-wiring pins.

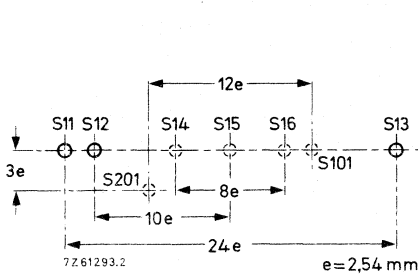

Fig. 5 Hole pattern of the printed-wiring board for a single potentiometer (viewed on component side).

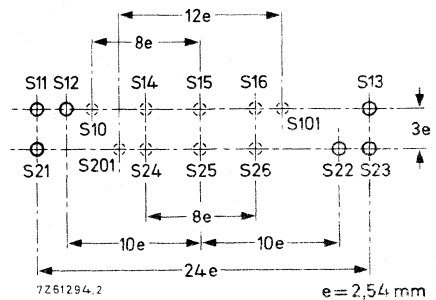

Fig. 6 Hole pattern of the printed-wiring board for a tandem potentiometer (viewed on component side).

Mounting

Potentiometers shown in Figs 1 and 2 are mounted with two self-tapping Parker screws, type 4N, according to UN-B1005 or UN-B1023 (min. length of thread 8 mm) making use of the holes in top and bottom or in front and back. Distance between the two holes is 80 mm.

Maximum torque for tightening: 500 mNm. (Minimum stripping torque: 700 mNm.)

Adjustment provisions

Four adjustment sliders are available:

- symmetrically placed, height 12,5 mm or 16 mm
- asymmetrically placed, height 12,5 mm or 16 mm

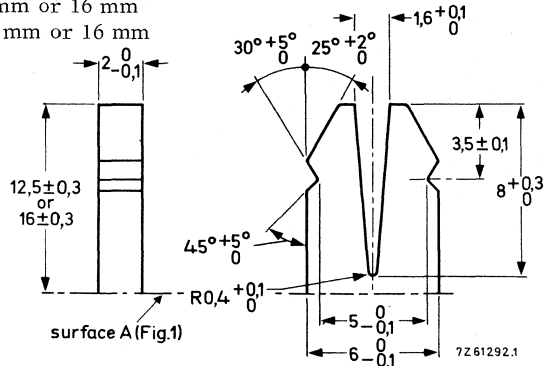
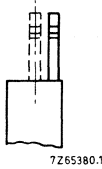

Fig. 7 End view of potentiometer with symmetrically (dotted lines) and asymmetrically placed adjustment slider.

Fig. 8 Adjustment slider.

TECHNICAL DATA

Unless stated otherwise, all electrical values have been determined at an ambient temperature of 15 to 35 °C, an air pressure of 860 to 1060 mbar and a relative humidity of 45 to 75%.

	nom. resist. (R_n) ¹⁾		resist. law acc. to Fig. 9	tap at	max. voltage (V)		max. terminal resist.	max. attenuation (dB)	max. contact resist. (% R_n)	limiting slider current at 40 °C (mA)
					at 40 °C	at 70 °C				
linear	220	Ω	a to d	1/3, 1/2 or 1/3 and 2/3	9,3	7,4	10 Ω	-	3	40
	470	Ω	a to d		14	11	10 Ω	-	3	22
	1	kΩ	a to d		20	16	25 Ω	-	3	16
	2,2	kΩ	a to d		30	23	25 Ω	-	3	11
	4,7	kΩ	a to d		41	34	25 Ω	-	2	7
	10	kΩ	a to d		63	50	35 Ω	-	2	5
	22	kΩ	a to d		93	74	35 Ω	-	2	3,5
	47	kΩ	a to d		137	108	35 Ω	-	2	2,2
	100	kΩ	a to d		200	158	100 Ω	-	2	1,4
	220	kΩ	a to d		296	234	125 Ω	-	2	1,0
	470	kΩ	a to d		410	342	250 Ω	-	2	0,65
	1	MΩ	a to d		500	500	1 kΩ	-	2	0,45
	2,2	MΩ	a to d		500	500	2,2 kΩ	-	2	0,32
	4,7	MΩ	a to d		500	500	4,7 kΩ	-	2	0,22
	10	MΩ	a to d		500	500	10 kΩ	-	2	0,16
330	Ω	a to d		11,5	9,1	10 Ω	-	3	30	

1) Measured between terminals S₁₁ and S₁₃ (or S₂₁ and S₂₃).

	nom. resist. (R_n) 1)	resist. law acc. to Fig. 9	tap at	max. voltage (V) at 40 °C at 70 °C		max. terminal resist.	max. attenuation (dB)	max. contact resist. (% R_n)	limiting slider current at 40 °C (mA)
logarithmic	1 k Ω	e to h	1/3, 1/2 or 1/3 and 2/3	14	11	25 Ω	50	4	10
	2, 2 k Ω	e to h		21	16	25 Ω	60	4	7
	4, 7 k Ω	e to h		31	24	25 Ω	60	4	4, 5
	10 k Ω	e to h		45	35	35 Ω	60	4	3, 2
	22 k Ω	e to h		66	52	35 Ω	70	4	2, 2
	47 k Ω	e to h		97	77	35 Ω	70	4	1, 4
	100 k Ω	e to h		141	112	50 Ω	80	4	1, 0
	220 k Ω	e to h		210	166	50 Ω	80	4	0, 7
	470 k Ω	e to h		310	242	100 Ω	80	4	0, 45
	1 M Ω	e to h		447	354	500 Ω	80	4	0, 32
2, 2 M Ω	e to h	500	500	500 Ω	80	4	0, 22		
4, 7 M Ω	e to h	500	500	1 k Ω	80	4	0, 14		
reversed logarithmic	1 k Ω	k, l	1/3	14	11	100 Ω	50	4	10
	2, 2 k Ω	k, l		21	16	100 Ω	60	4	7
	4, 7 k Ω	k, l		31	24	100 Ω	60	4	4, 5
	10 k Ω	k, l		45	35	250 Ω	60	4	3, 2
	22 k Ω	k, l		66	52	250 Ω	70	4	2, 2
	47 k Ω	k, l		97	77	500 Ω	70	4	1, 4
	100 k Ω	k, l		141	112	2, 5 k Ω	80	4	1, 0
	220 k Ω	k, l		210	166	2, 5 k Ω	80	4	0, 7
	470 k Ω	k, l		310	242	5 k Ω	80	4	0, 45
	1 M Ω	k, l		447	354	25 k Ω	80	4	0, 32
2, 2 M Ω	k, l	500	500	25 k Ω	80	4	0, 22		
4, 7 M Ω	k, l	500	500	50 k Ω	80	4	0, 14		
semi logarithmic	470 Ω	m to p	1/3, 1/2 or 1/3 and 2/3	9, 7	7, 7	10 Ω	40	5	14
	1 k Ω	m to p		14	11	25 Ω	50	4	10
	2, 2 k Ω	m to p		21	16	25 Ω	50	4	7
	4, 7 k Ω	m to p		31	24	25 Ω	60	4	4, 5
	10 k Ω	m to p		45	35	35 Ω	60	4	3, 2
	22 k Ω	m to p		66	52	35 Ω	70	4	2, 2
	47 k Ω	m to p		97	77	35 Ω	70	4	1, 4
	100 k Ω	m to p		141	112	50 Ω	80	4	1, 0
	220 k Ω	m to p		210	166	100 Ω	80	4	0, 7
	470 k Ω	m to p		310	242	250 Ω	80	4	0, 45
1 M Ω	m to p	447	354	500 Ω	80	4	0, 32		
2, 2 M Ω	m to p	500	500	1 k Ω	80	4	0, 22		
4, 7 M Ω	m to p	500	500	2, 5 k Ω	80	4	0, 14		

1) Measured between terminals S_{11} and S_{13} (or S_{21} and S_{23}).

2) Measured between terminals S_{11} and S_{12} (or S_{21} and S_{22}); slider placed at the beginning of the travel.

3) Measured between terminals S_{13} and S_{12} (or S_{23} and S_{22}); slider placed at the end of the travel.

balance	nom. resist. (R_N) ¹⁾	resist. law acc. to Fig. 9	tap at	max. voltage (V)		max. terminal resist.	max. attenuation (dB)	max. contact resist. (% R_N)	limiting slider current at 40 °C (mA)
				at 40°C	at 70 °C				
	10 kΩ	q	-	45	35	-	-	4	3,2
	22 kΩ	q	-	66	52	-	-	4	2,2
	47 kΩ	q	-	97	77	-	-	4	1,4
	100 kΩ	q	-	141	112	-	-	4	1,0
	220 kΩ	q	-	250	166	-	-	4	0,7
	470 kΩ	q	-	310	242	-	-	4	0,45
	1 MΩ	q	-	447	354	-	-	4	0,32
	2,2 MΩ	q	-	500	500	-	-	4	0,22
	4,7 MΩ	q	-	500	500	-	-	4	0,14

1) Measured between terminals S₁₁ and S₁₃ (or S₂₁ and S₂₃)

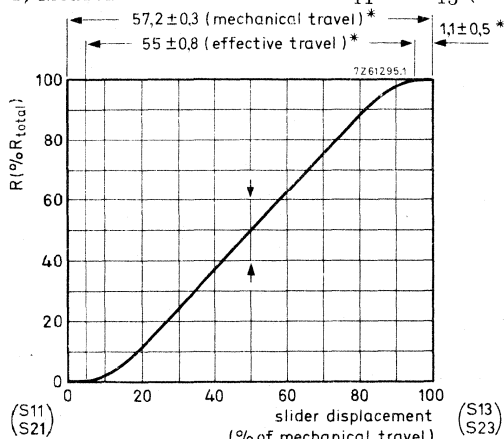

Fig. 9a Linear law; without tap

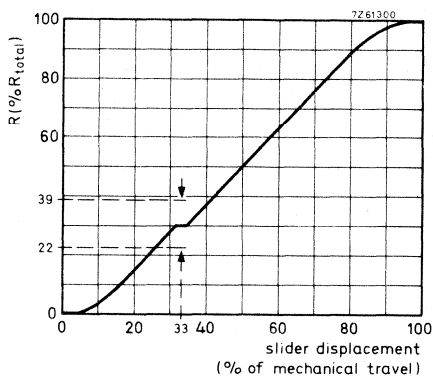

Fig. 9b Linear law; tap at 1/3

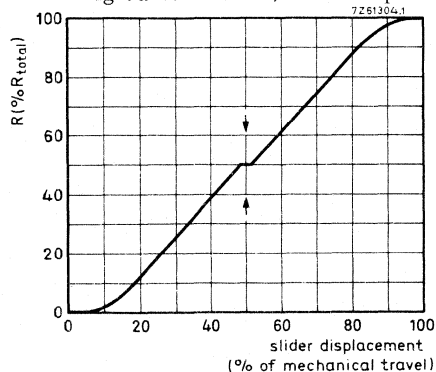

Fig. 9c Linear law; tap at 1/2

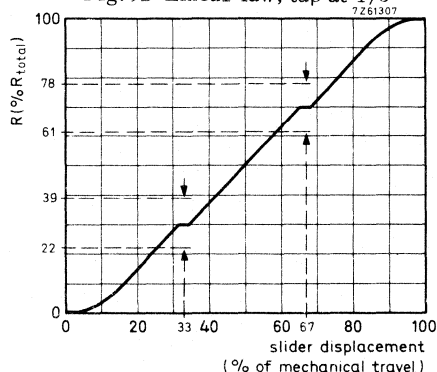

Fig. 9d Linear law; taps at 1/3 and 2/3

*) Valid for all graphs.

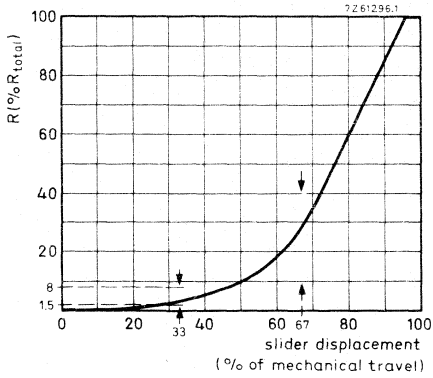

Fig. 9e Logarithmic law; without tap

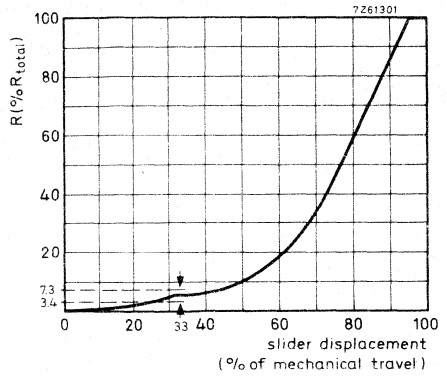

Fig. 9f Logarithmic law; tap at 1/3

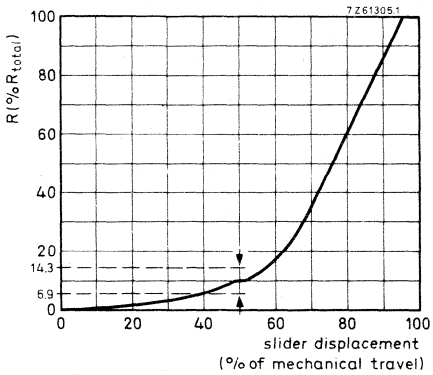

Fig. 9g Logarithmic law; tap at 1/2

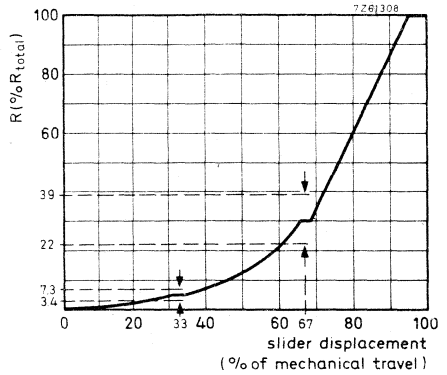

Fig. 9h Logarithmic law; taps at 1/3 and 2/3

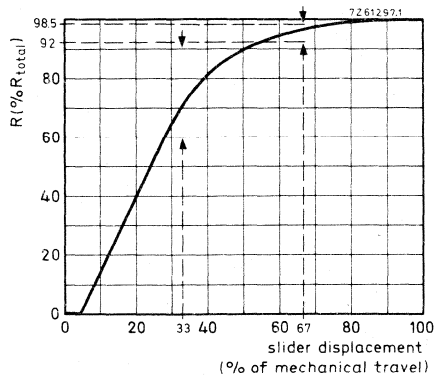

Fig. 9k Reversed logarithmic law; without tap

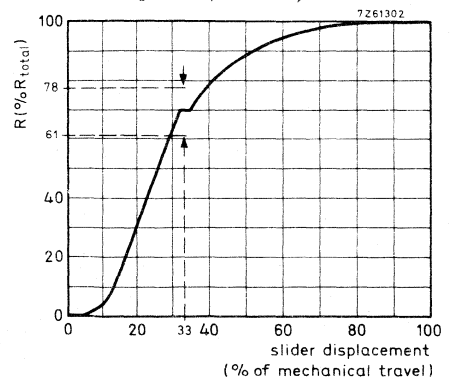

Fig. 9l Reversed logarithmic law; tap at 1/3

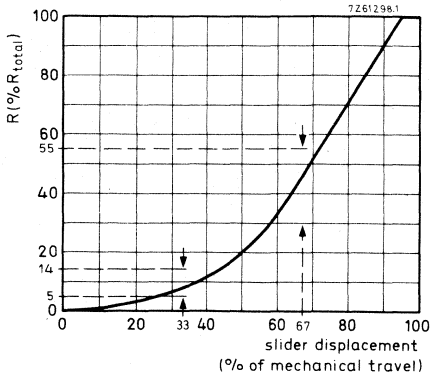

Fig. 9m Semi-logarithmic law; without tap

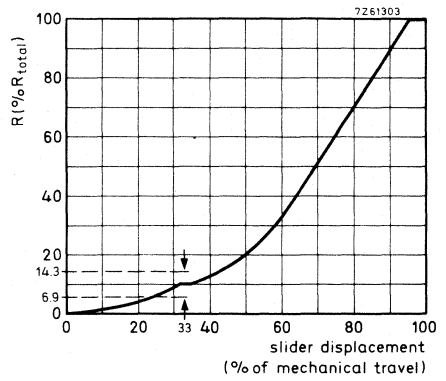

Fig. 9n Semi-logarithmic law; tap at 1/3

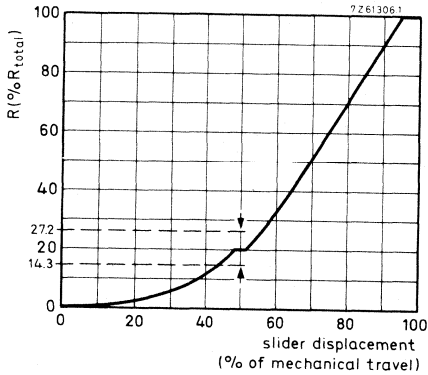

Fig. 9o Semi-logarithmic law; tap at 1/2

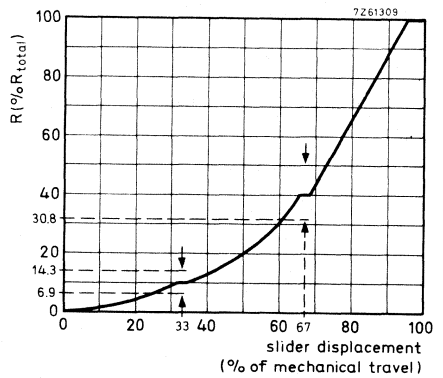

Fig. 9p Semi-logarithmic law; taps at 1/3 and 2/3

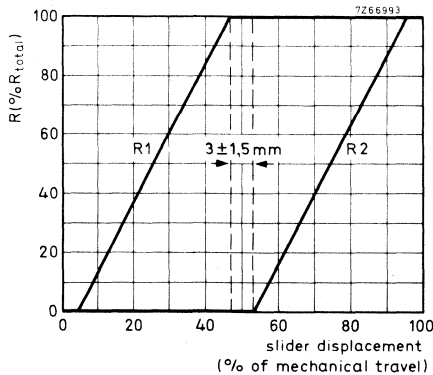

Fig. 9q Balance potentiometers (tandems only)

Resistance law and tolerance	linear, logarithmic, reversed logarithmic, semi-logarithmic, balance, see Figs. 9a to 9q
Tolerance on nominal resistance	$\pm 20\%$
Minimum resistance at the tap(s)	$\leq 10 \Omega$
Insulation resistance (versions with external screening), initially	$> 10^4 \text{ M}\Omega$
Maximum dissipation (P_{\max})	
linear resistance law, at 40 °C	0,4 W
at 70 °C	0,25 W
logarithmic, reversed logarithmic and semi-logarithmic resistance law, at 40 °C	0,2 W
at 70 °C	0,125 W
Test voltage for 1 min	1000 V, 50 Hz
Working temperature range	-10 to +70 °C
Storage temperature range	-25 to +70 °C
Category (IEC68)	10/070/21
Operating force (F) 1)	
single potentiometers	0,75 - 2 N
tandem potentiometers	1,25 - 2,5 N
	$\left. \begin{array}{l} 0,75 - 2 \text{ N} \\ 1,25 - 2,5 \text{ N} \end{array} \right\} \frac{F_{\max}}{F_{\min}} \leq 1,5$
Permissible force with slider at end stop 1)	$\leq 50 \text{ N}$ (Fig. 10a)
Permissible load perpendicular to the direction of movement 1)	$\leq 20 \text{ N}$ (Fig. 10b)
Permissible torque on slider 1)	$\leq 30 \text{ Ncm}$ (Fig. 10c)
Permissible axial force on slider (push and pull) 1)	$\leq 50 \text{ N}$

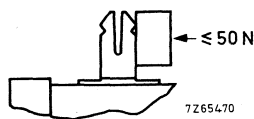

Fig. 10a

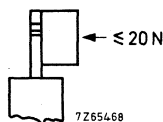

Fig. 10b

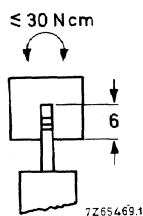

Fig. 10c

Effective travel of slider contact	$55 \pm 0,8 \text{ mm}$	} see also Fig. 9a
Mechanical travel of slider contact	$57,2 \pm 0,3 \text{ mm}$	
Life	10 000 x in both directions	

1) Measured for 5 s on a free slider without knob.

→ Ganging tolerance *

Linear resistance law, without tap, at values between 10 and 90% of R_{TOT}	< 2 dB
Linear resistance law, with tap, at values between 10 and 90% of R_{TOT}	< 3 dB
Logarithmic, reversed logarithmic and semi-logarithmic resistance law, without tap, at attenuations between - 0 and -20 dB	< 2 dB
at attenuations between -20 and -30 dB	< 3 dB
at attenuations between -30 and -40 dB	< 4 dB
Logarithmic, reversed logarithmic and semi-logarithmic resistance law, with tap, at attenuations between 0 and -20 dB	< 2 dB
at attenuations between -20 and -30 dB	< 3 dB
at attenuations between -30 and -34 dB	< 4 dB

Crosstalk * (measured according to Fig. 11)

resistance value	potentiometers with internal screening		potentiometers without internal screening	
	at 1 kHz	at 10 kHz	at 1 kHz	at 10 kHz
220 Ω to 100 k Ω	≥ 70 dB	≥ 55 dB	≥ 60 dB	≥ 45 dB
100 k Ω to 220 k Ω	≥ 60 dB	≥ 50 dB	≥ 50 dB	≥ 40 dB
220 k Ω to 470 k Ω	≥ 60 dB	≥ 50 dB	≥ 50 dB	≥ 40 dB
470 k Ω to 2,2 M Ω	≥ 50 dB	≥ 40 dB	≥ 40 dB	≥ 30 dB

Fig. 11 Crosstalk = $20 \log \frac{V_1}{V_2}$.

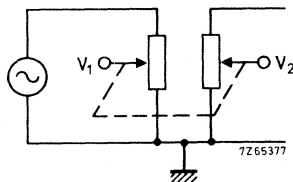

→ MARKING

The potentiometers are marked at the side with the nominal resistance value, resistance law, period and year of manufacture.

* For tandem potentiometers only.

AVAILABLE VERSIONS AND COMPOSITION OF THE CATALOGUE NUMBER

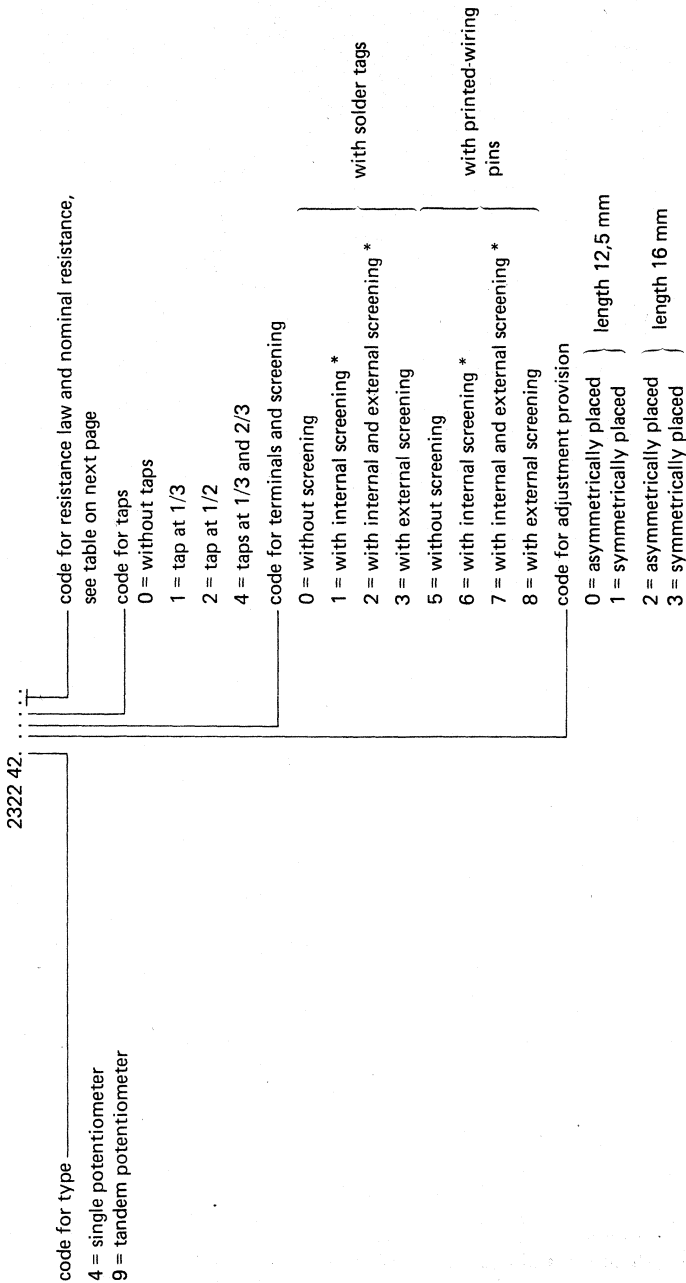

Note

Detent slide potentiometers (11 click, 31 click and centre click types) can be supplied on request.

* Only for tandem potentiometers.



nominal resistance	code in catalogue number				
	linear law	log. law	reversed log. law	semi- log. law	balance
220 Ω	02				
470 Ω	03				
1 k Ω	04	24	44	63	
2, 2 k Ω	05	25	45	64	
4, 7 k Ω	06	26	46	65	
10 k Ω	07	27	47	66	
22 k Ω	08	28	48	67	87
47 k Ω	09	29	49	68	88
100 k Ω	11	31	51	69	89
220 k Ω	12	32	52	71	91
470 k Ω	13	33	53	72	92
1 M Ω	14	34	54	73	93
2, 2 M Ω	15	35	55	74	94
4, 7 M Ω	16	36	56	75	95
10 M Ω	17			76	96
330 Ω	19				

1) Only available without tap.

2) Only available without tap and with tap at 1/3 of the total travel.

40 mm SLIDE CARBON POTENTIOMETERS

QUICK REFERENCE DATA

Nominal resistance values	
linear resistance law	220 Ω – 4,7 M Ω
logarithmic, reversed logarithmic and semi-logarithmic resistance law	1 k Ω – 2,2 M Ω
Maximum dissipation at 40 °C	
linear resistance law	0,25 W
logarithmic, reversed logarithmic and semi-logarithmic resistance law	0,125 W
Climatic category (IEC68)	10/070/21

DESCRIPTION

This slide carbon potentiometer series includes two types:

- single potentiometers, for general purposes,
- tandem potentiometers, for stereophonic purposes.

The single potentiometers comprise a straight carbon track, which is fitted on to a base plate of resin bonded paper, mounted in a housing of black synthetic resin.

The tandem potentiometers are composed of two carbon tracks, fitted on base plates of resin bonded paper, which are situated in one housing. The base plates are placed in such a way that the tracks are opposite each other.

The terminals S_{11}, S_{13} (single) and $S_{11}/S_{21}, S_{13}/S_{23}$ (tandem) are connected to the ends of the carbon track (see Figs 1 and 2); terminals S_{12} (single) and S_{22} (tandem) are connected to the slider contact. The potentiometer can be supplied with a tap at 1/2, 1/3 or at 1/3 and 2/3 of the total travel.

Both types are available with or without a metal screening at the outer surface of the potentiometer housing, providing general protection against external interference. The tandem potentiometers can also be supplied with a metal screening between the two carbon tracks, thus preventing crosstalk.

The potentiometers are available with different connecting terminals and adjustment provisions.

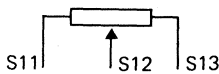

Single type

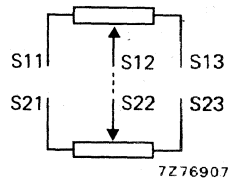

Tandem type

Dimensions in mm

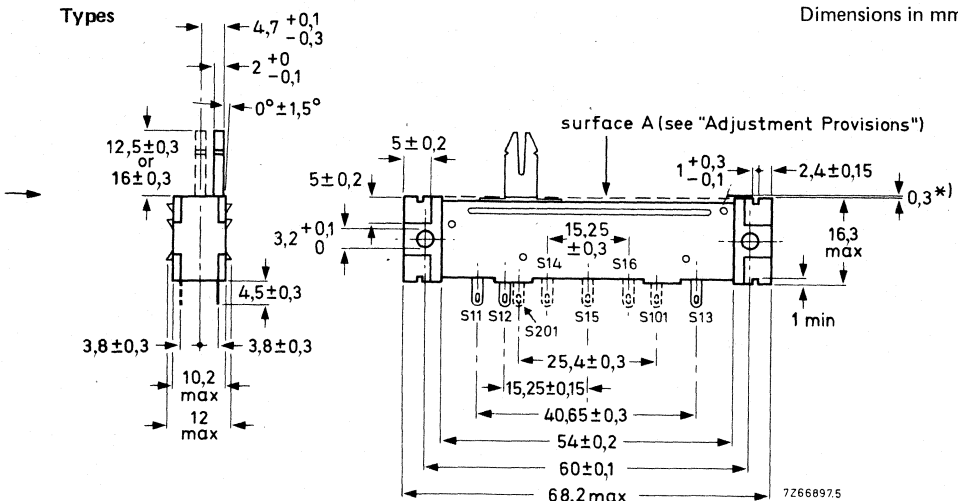

Fig. 1 Single slide potentiometer with solder tags.

- S11, S13 = beginning and end terminals respectively
- S12 = slider terminal
- S14, S15, S16 = tap terminal at 1/3, 1/2 and 2/3 of the total travel respectively
- S101, S201 = earthing terminals (connected to external screening).

(1) Only for potentiometers with external screening.

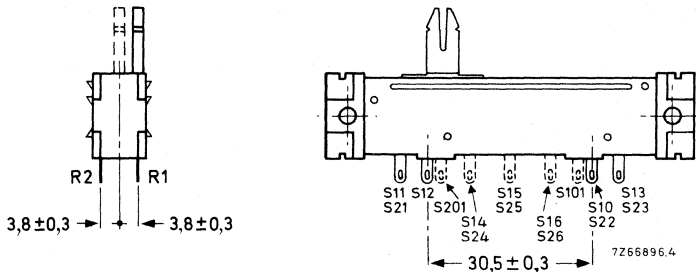

Fig. 2 Tandem slide potentiometer with solder tags.

Dimensions are identical with those in Fig. 1 except as shown.

- | | | | |
|--|------------------------|---|------------------------|
| S11, S13 = beginning and end terminals resp. | } potentiometer 1 (R1) | S21, S23 = beginning and end terminals resp. | } potentiometer 2 (R2) |
| S12 = slider terminal | | S22 = slider terminal | |
| S14, S15, S16 = tap terminal at 1/3, 1/2 and 2/3 of the total travel resp. | | S24, S25 = tap terminal at 1/3, 1/2 and 2/3 of the total travel resp. | |

S101, S201 = earthing terminals (connected to external screening)

S10 = earthing terminal (connected to internal screening).

To determine the side on which potentiometer R1 is situated, the customer should look for the marking: this is always placed at the beginning of R1.

Connecting terminals

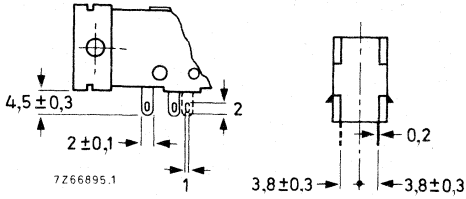

Fig. 3 Solder tags.

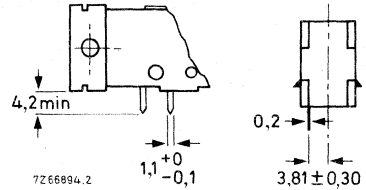

Fig. 4 Printed-wiring pins.

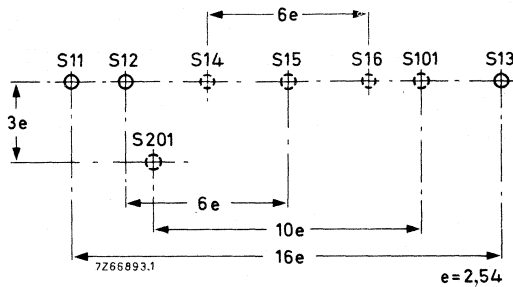

Fig. 5 Hole pattern of the printed-wiring board for a single potentiometer (viewed on component side).

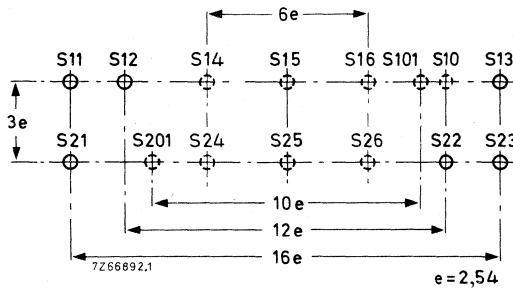

Fig. 6 Hole pattern of the printed-wiring board for a tandem potentiometer (viewed on component side).

Mounting

The potentiometers are available with screw-mounting facility (M3), making use of the holes in top and bottom.

Potentiometers without screw-mounting facility are also available.

Adjustment provisions

Four adjustment sliders are available:

- symmetrically placed, height 12,5 mm or 16 mm
- asymmetrically placed, height 12,5 mm or 16 mm

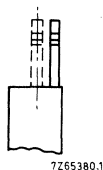

Fig. 7 End view of potentiometer with symmetrically (dotted lines) and asymmetrically placed adjustment slider.

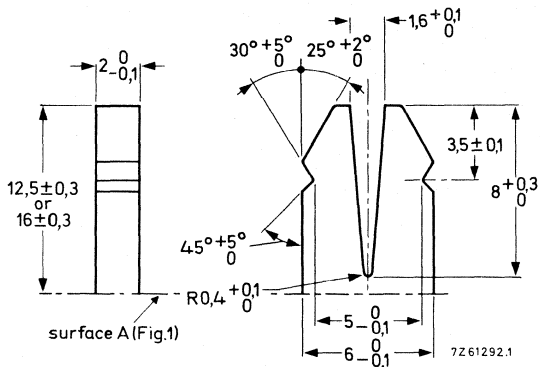

Fig. 8 Adjustment slider.

TECHNICAL DATA

Unless stated otherwise, all electrical values have been determined at an ambient temperature of 15 to 35 °C, an air pressure of 860 to 1060 mbar and a relative humidity of 45 to 75%.

	nom. resist. (R _n) *	resist. law acc. to Fig. 9	tap at	max. voltage (V)		max. terminal resist.	max. attenuation (dB)	max. contact resist. (%R _n)	limiting slider current at 40 °C (mA)
				at 40 °C	at 70 °C				
linear	220 Ω	a to d	1/3, 1/2 or 1/3 and 2/3	7,4	5,2	10 Ω	—	3	33
	470 Ω	a to d		11	7,7	10 Ω	—	3	23
	1 kΩ	a to d		16	11	25 Ω	—	3	16
	2,2 kΩ	a to d		23	16	25 Ω	—	3	10
	4,7 kΩ	a to d		34	24	25 Ω	—	2,5	7,2
	10 kΩ	a to d		50	35	35 Ω	—	2,5	5
	22 kΩ	a to d		74	52	35 Ω	—	2,5	3,3
	47 kΩ	a to d		108	77	35 Ω	—	2,5	2,3
	100 kΩ	a to d		158	112	100 Ω	—	2,5	1,6
	220 kΩ	a to d		234	166	125 Ω	—	2,5	1,0
	470 kΩ	a to d		342	242	250 Ω	—	2,5	0,72
	1 MΩ	a to d		500	354	1 kΩ	—	2,5	0,50
	2,2 MΩ	a to d		500	500	2,2 kΩ	—	2,5	0,33
	4,7 MΩ	a to d		500	500	4,7 kΩ	—	2,5	0,23
330 Ω	a to d		9,1	6,4	10 Ω	—	3	27	

* Measured between terminals S₁₁ and S₁₃ (or S₂₁ and S₂₃).

	nom. resist. (R_n) ¹⁾	resist. law acc. to Fig. 9	tap at	max. voltage (V)		max. terminal resist.	max. attenuation (dB)	max. contact resist. (% R_n)	limiting slider current at 40°C (mA)
				at 40°C	at 70°C				
logarithmic	1 kΩ	e to h	1/3, 1/2 or 1/3 and 2/3	11	7, 9	25 Ω	50	4	11
	2, 2 kΩ	e to h		16	12	25 Ω	60	4	7, 3
	4, 7 kΩ	e to h		24	17	25 Ω	60	4	5, 1
	10 kΩ	e to h		35	25	35 Ω	60	4	3, 5
	22 kΩ	e to h		52	37	35 Ω	70	4	2, 4
	47 kΩ	e to h		77	54	35 Ω	70	4	1, 6
	100 kΩ	e to h		112	79	50 Ω	80	4	1, 1
	220 kΩ	e to h		166	117	50 Ω	80	4	0, 73
	470 kΩ	e to h		242	170	100 Ω	80	4	0, 51
reversed logarithmic	1 MΩ	e to h	1/3, 1/2 or 1/3 and 2/3	354	250	500 Ω	80	4	0, 35
	2, 2 MΩ	e to h		500	370	500 Ω	80	4	0, 24
	1 kΩ	k to n		11	7, 9	100 Ω	50	4	11
	2, 2 kΩ	k to n		16	12	100 Ω	60	4	7, 3
	4, 7 kΩ	k to n		24	17	100 Ω	60	4	5, 1
	10 kΩ	k to n		35	25	250 Ω	60	4	3, 5
	22 kΩ	k to n		52	37	250 Ω	70	4	2, 4
	47 kΩ	k to n		77	54	500 Ω	70	4	1, 6
	100 kΩ	k to n		112	79	2, 5 kΩ	80	4	1, 1
semi logarithmic	220 kΩ	k to n	1/3, 1/2 or 1/3 and 2/3	166	117	2, 5 kΩ	80	4	0, 73
	470 kΩ	k to n		242	170	5 kΩ	80	4	0, 51
	1 MΩ	k to n		354	250	25 kΩ	80	4	0, 35
	2, 2 MΩ	k to n		500	370	25 kΩ	80	4	0, 24
	470 Ω	o to r		7, 7	5, 4	25 Ω	50	4	16
	1 kΩ	o to r		11	7, 9	25 Ω	50	4	11
	2, 2 kΩ	o to r		16	12	25 Ω	50	4	7, 3
	4, 7 kΩ	o to r		24	17	25 Ω	60	4	5, 1
	10 kΩ	o to r		35	25	35 Ω	60	4	3, 5
22 kΩ	o to r	52	37	35 Ω	70	4	2, 4		
47 kΩ	o to r	77	54	35 Ω	70	4	1, 6		
100 kΩ	o to r	112	79	50 Ω	80	4	1, 1		
220 kΩ	o to r	166	117	100 Ω	80	4	0, 73		
470 kΩ	o to r	242	170	250 Ω	80	4	0, 51		
1 MΩ	o to r	354	250	500 Ω	80	4	0, 35		
2, 2 MΩ	o to r	500	370	1000 Ω	80	4	0, 24		

1) Measured between terminals S₁₁ and S₁₃ (or S₂₁ and S₂₃).

2) Measured between terminals S₁₁ and S₁₂ (or S₂₁ and S₂₂); slider placed at the beginning of the travel.

3) Measured between terminals S₁₃ and S₁₂ (or S₂₃ and S₂₂); slider placed at the end of the travel.

	nom. resist. (R _n) ¹⁾	resist. law acc. to Fig. 9	tap at	max. voltage (V)		max. terminal resist.	max. attenuation (dB)	max. contact resist. (% R _n)	limiting slider current at 40 °C (mA)
				at 40 °C	at 70 °C				
balance	10 kΩ	s	-	35	25	-	-	4	3,5
	22 kΩ	s	-	52	37	-	-	4	2,4
	47 kΩ	s	-	77	54	-	-	4	1,6
	100 kΩ	s	-	112	79	-	-	4	1,1
	220 kΩ	s	-	166	117	-	-	4	0,73
	470 kΩ	s	-	242	170	-	-	4	0,51
	1 MΩ	s	-	354	250	-	-	4	0,35
	2,2 MΩ	s	-	500	370	-	-	4	0,24

1) Measured between terminals S₁₁ and S₁₃ (or S₂₁ and S₂₃).

*) Valid for all graphs.

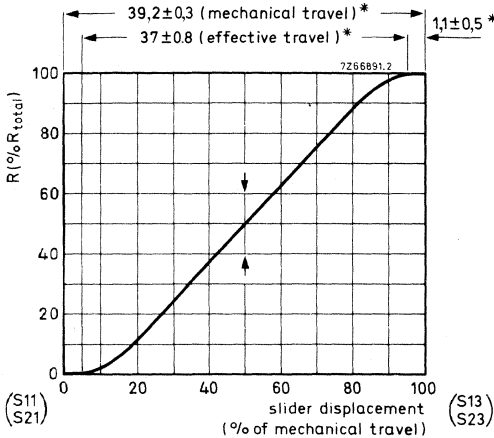

Fig. 9a Linear law; without tap.

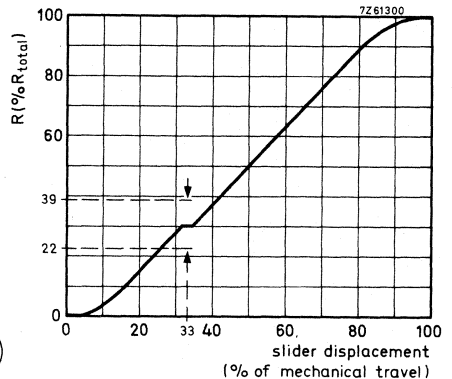

Fig. 9b Linear law; tap at 1/3.

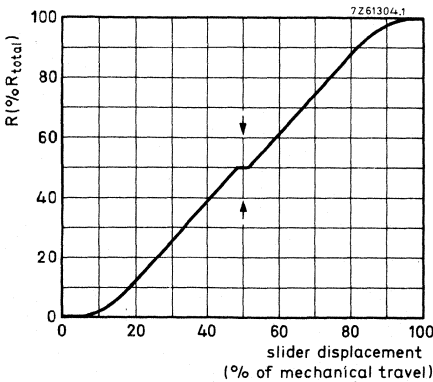

Fig. 9c Linear law; tap at 1/2.

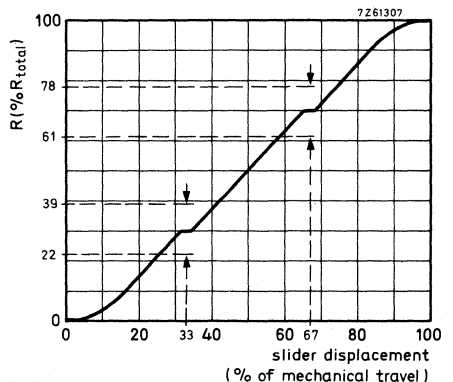

Fig. 9d Linear law; taps at 1/3 and 2/3.

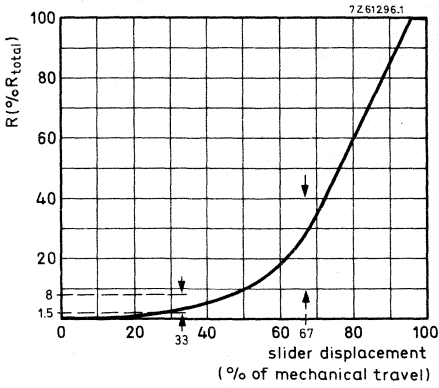

Fig. 9e Logarithmic law; without tap.

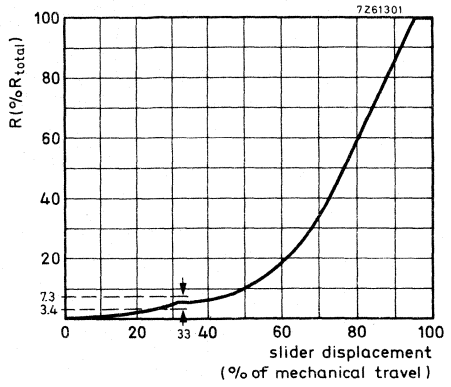

Fig. 9f Logarithmic law; tap at 1/3.

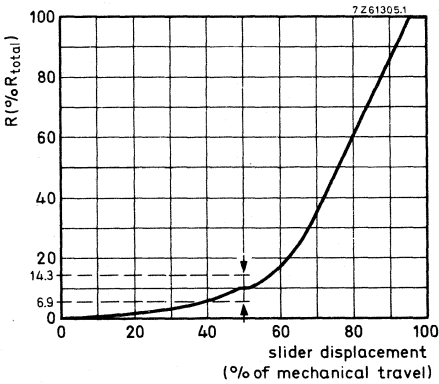

Fig. 9g Logarithmic law; tap at 1/2.

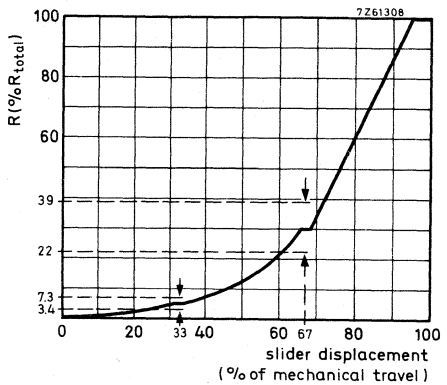

Fig. 9h Logarithmic law; taps at 1/3 and 2/3.

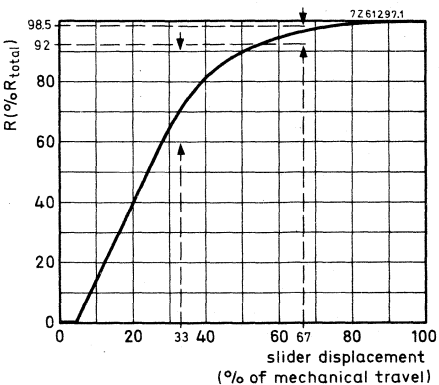

Fig. 9k Reversed logarithmic law, without tap.

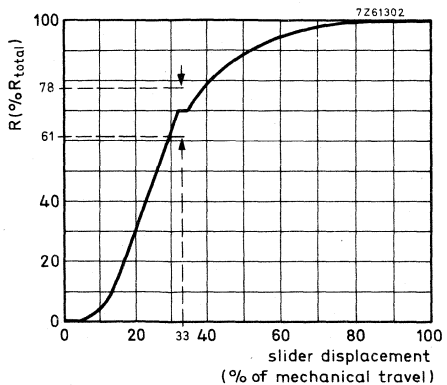

Fig. 9l Reversed logarithmic law; tap at 1/3.



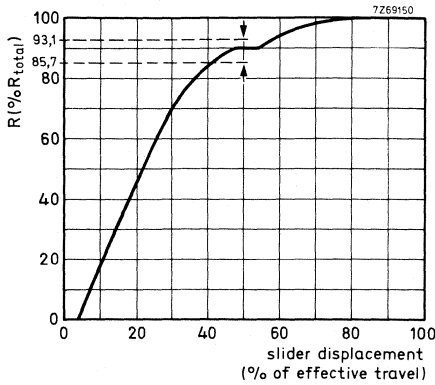

Fig. 9m Reversed logarithmic law; tap at 1/2.

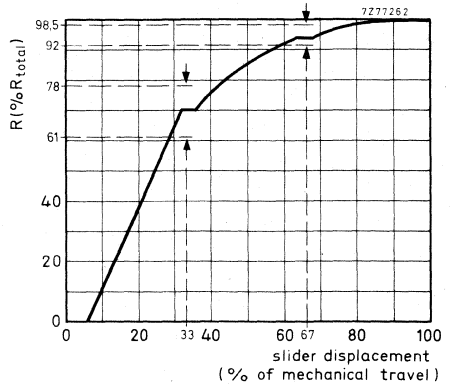

Fig. 9n Reversed logarithmic law; taps at 1/3 and 2/3.

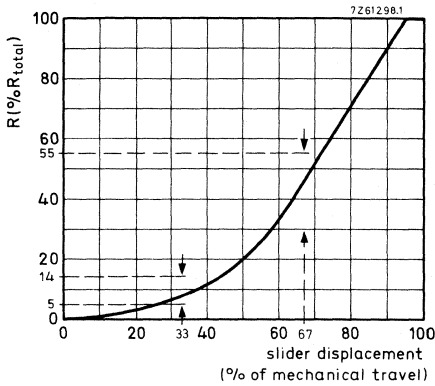

Fig. 9o Semi-logarithmic law; without tap.

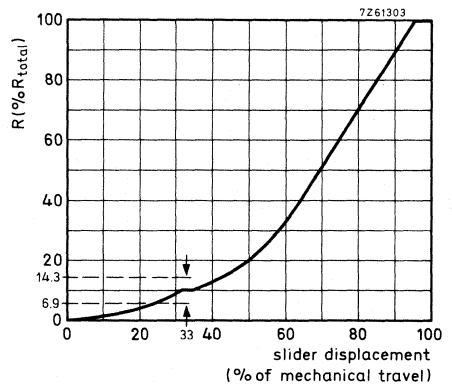

Fig. 9p Semi-logarithmic law; tap at 1/3.

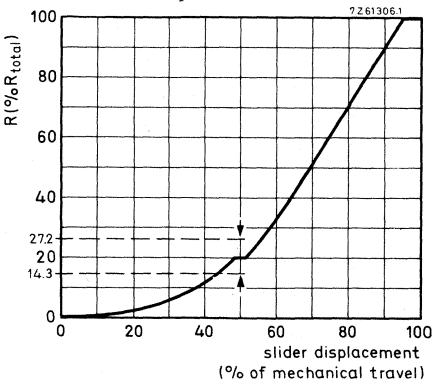

Fig. 9q Semi-logarithmic law; tap at 1/2.

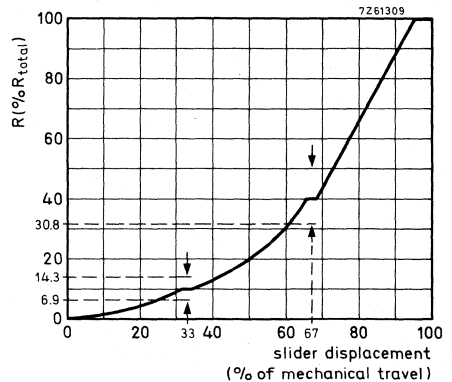

Fig. 9r Semi-logarithmic law; taps at 1/3 and 2/3.



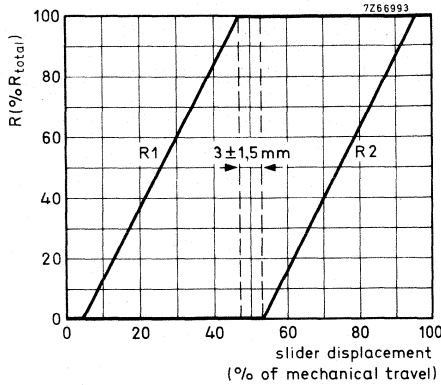

Fig. 9s Balance potentiometers.
(for tandems only)

Resistance law and tolerance	linear, logarithmic, reversed logarithmic, semi-logarithmic, balance, see Figs. 9a to 9s
Tolerance on nominal resistance	$\pm 20\%$
Minimum resistance at the tap	$\leq 10 \Omega$
Insulation resistance (versions with external screening), initially	$> 10^4 \text{ M}\Omega$
Maximum dissipation (P_{max})	
linear resistance law, at 40 °C	0,25 W
linear resistance law, at 70 °C	0,125 W
logarithmic, reversed logarithmic and semi-logarithmic resistance law, at 40 °C	0,125 W
semi-logarithmic resistance law, at 70 °C	0,0625 W
Test voltage for 1 min (versions with external screening)	1000 V, 50 Hz
Working temperature range	-10 to +70 °C
Storage temperature range	-25 to +70 °C
Climatic category (IEC68)	10/070/21
Operating force (F) *	
single potentiometers	0,75 - 2 N
tandem potentiometers	1,25 - 2,5 N
	$\left. \begin{array}{l} 0,75 - 2 \text{ N} \\ 1,25 - 2,5 \text{ N} \end{array} \right\} \frac{F_{max}}{F_{min}} \leq 1,3$
Permissible force with slider at end stop *	$\leq 50 \text{ N}$ (Fig. 10a, next page)
Permissible load perpendicular to the direction of movement *	$\leq 20 \text{ N}$ (Fig. 10b, next page)
Permissible torque on slider *	$\leq 30 \text{ Ncm}$ (Fig. 10c, next page)
Permissible axial force on slider (push and pull) *	$\leq 50 \text{ N}$

* Measured for 5 s on a free slider without knob.

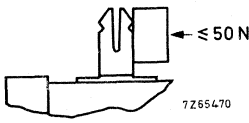

Fig. 10a

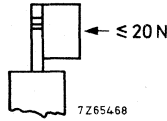

Fig. 10b

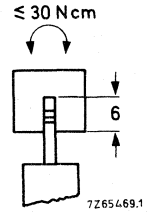

Fig. 10c

Effective travel of slider contact	$37 \pm 0,8 \text{ mm}$	} see also Fig.9a
Mechanical travel of slider contact	$39,2 \pm 0,3$	
Life	10 000 x in both directions	
Ganging tolerance*		
linear resistance law, without tap		
at values between 10 and 90% of R_{tot}	< 2 dB	
linear resistance law, with tap	< 3 dB	
logarithmic, reversed logarithmic and		
semi-logarithmic resistance law, without tap		
at attenuations between 0 and -20 dB	< 2 dB	
at attenuations between -20 and -30 dB	< 3 dB	
at attenuations between -30 and -40 dB	< 4 dB	
logarithmic, reversed logarithmic and		
semi-logarithmic resistance law, with tap		
at attenuations between 0 and -20 dB	< 2 dB	
at attenuations between -20 and -30 dB	< 3 dB	
at attenuations between -30 and -34 dB	< 4 dB	

Note: Potentiometers with reversed logarithmic law are measured as those with logarithmic law.

* For tandem potentiometers only.

Crosstalk * (measured according to Fig. 11).

resistance value	potentiometers with internal screening		potentiometers without internal screening	
	at 1 kHz	at 10 kHz	at 1 kHz	at 10 kHz
220 Ω to 100 kΩ	≥ 70 dB	≥ 55 dB	≥ 60 dB	≥ 45 dB
100 kΩ to 220 kΩ	≥ 60 dB	≥ 50 dB	≥ 50 dB	≥ 40 dB
220 kΩ to 470 kΩ	≥ 60 dB	≥ 50 dB	≥ 50 dB	≥ 40 dB
470 kΩ to 2,2 MΩ	≥ 50 dB	≥ 40 dB	≥ 40 dB	≥ 30 dB

Fig. 11 Crosstalk = $20 \log \frac{V_1}{V_2}$.

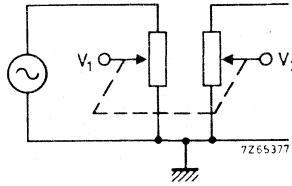

Marking

The potentiometers are marked at the side with the nominal resistance value, resistance law, period and year of manufacture.



* For tandem potentiometers only.

AVAILABLE VERSIONS AND COMPOSITION OF THE CATALOGUE NUMBER

2322 43.

code for type and screw-mounting facility

- 0 = without screw-mounting facility } single
- 1 = with screw-mounting facility }
- 5 = without screw-mounting facility } tandem
- 6 = with screw-mounting facility }

code for resistance law and nominal resistance, see table on next page.

code for tap

- 0 = without tap
- 1 = tap at 1/3
- 2 = tap at 1/2
- 4 = taps at 1/3 and 2/3

code for terminals and screening

- 0 = without screening
- 1 = with internal screening *
- 2 = with internal and external screening *
- 3 = with external screening
- 5 = without screening
- 6 = with internal screening *
- 7 = with internal and external screening *
- 8 = with external screening

1 or 6

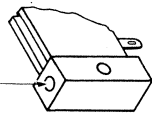

7278465.1

with solder tags

with printed-wiring pins

code for adjustment provision

- 0 = asymmetrically placed } length 12,5 mm
- 1 = symmetrically placed }
- 2 = asymmetrically placed } length 16 mm
- 3 = symmetrically placed }

Note

Detent slide potentiometers (11 click-, 21 click- and centre click types) can be supplied on request.

* Only for tandem potentiometers.

nominal resistance	code in catalogue number				
	linear law	log. law	reversed log. law	semi- log. law	balance
220 Ω	02				
470 Ω	03			63	
1 $k\Omega$	04	24	44	64	
2,2 $k\Omega$	05	25	45	65	
4,7 $k\Omega$	06	26	46	66	
10 $k\Omega$	07	27	47	67	87
22 $k\Omega$	08	28	48	68	88
47 $k\Omega$	09	29	49	69	89
100 $k\Omega$	11	31	51	71	91
220 $k\Omega$	12	32	52	72	92
470 $k\Omega$	13	33	53	73	93
1 $M\Omega$	14	34	54	74	94
2,2 $M\Omega$	15	35	55	75	95
4,7 $M\Omega$	16				
330 Ω	19				

only
available
without
tap



13 mm CARBON CONTROL POTENTIOMETERS



RZ 27512-2

Nominal resistance values
Resistance law

4, 7, 10 and 22 kΩ
linear and logarithmic

GENERAL

These potentiometers are destined for use in **miniaturized** electronic equipment such as hearing aids, small radio sets, etc.

On account of their application a special construction has been used, which makes mounting of a control knob superfluous.

The potentiometers can be fixed on a chassis with the supplied mounting nut, catalogue number 4322 047 09530.

Dimensions in mm

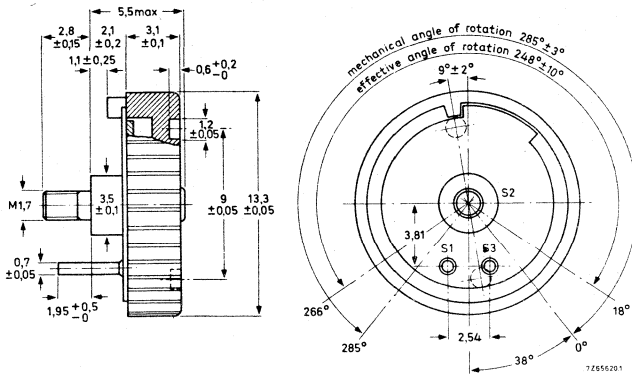

S₁, S₂, S₃ = potentiometer terminals (S₁ and S₃ are connected to the ends of the carbon track; S₂ is connected to the slider contact)

TECHNICAL PERFORMANCE

Nominal resistance values	4, 7, 10 and 22 k Ω
Tolerance on the nominal resistance	$\pm 20\%$
Resistance law	linear and logarithmic
Contact resistance between carbon track and slider	
linear resistance law	$\leq 5\%$ of R_n
logarithmic resistance law	$\leq 10\%$ of R_n
Terminal resistance	
linear resistance law	$\leq 1\%$ of R_n
logarithmic resistance law	$\leq 0,1\%$ of R_n
Insulation resistance	$> 1 \text{ M}\Omega$
Maximum attenuation	$\geq 60 \text{ dB}$
Maximum voltage over the resistance element	10 V d. c.
Current through slider	$\leq 1 \text{ mA}$
Test voltage for 1 min	100 V, 50 Hz
Working-temperature range	-10 to +70 °C
Effective angle of rotation	248 $\pm 10^\circ$
Mechanical angle of rotation	285 $\pm 3^\circ$
Operating torque	0, 2 - 1 Ncm
Maximum permissible torque with slider at end stop	5 Ncm
Life	in excess of 15 000 cycles

COMPOSITION OF THE CATALOGUE NUMBER

2322 440 100..

06 = 4,7 k Ω	} linear resistance law
07 = 10 k Ω	
08 = 22 k Ω	
26 = 4,7 k Ω	} logarithmic resistance law
27 = 10 k Ω	
28 = 22 k Ω	

CARBON POTENTIOMETERS for t.v. focus trimming

QUICK REFERENCE DATA	
Resistance values	470 k Ω , 2,7 M Ω , 10 M Ω
Resistance law	linear
Maximum dissipation at 40 °C	1 W
Test voltage	10 000 V, 50 Hz
Category (IEC 68)	10/070/21

APPLICATION

These potentiometers have been developed for focus applications in television receivers.

DESCRIPTION

The potentiometers comprise a carbon track, which is fitted on to a ceramic base plate and housed in a non-inflammable plastic case. The terminals S₁ and S₃ are connected to the ends of the carbon track; terminal S₂ is connected via a contact ring to the slider contact.

Dimensions in mm

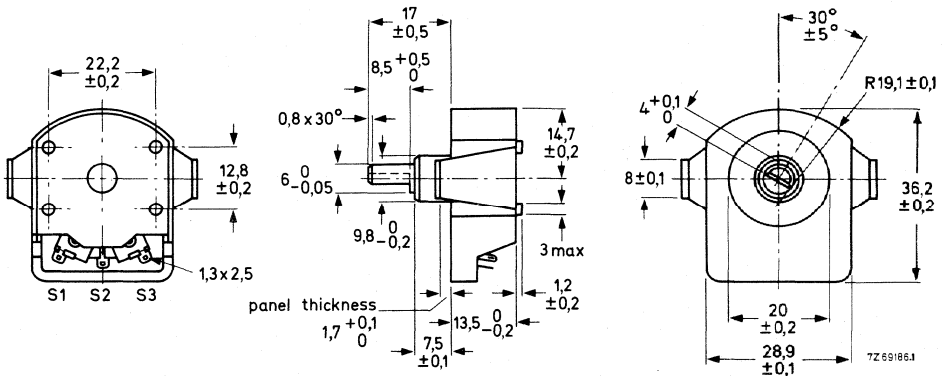

Fig. 1. Potentiometers 2322 460 900. .; spindle in fully counter-clockwise position.

MOUNTING

The potentiometers can be fitted to a panel by means of the two mounting lugs. The hole pattern is given in Fig. 2.

The requisite panel thickness is 1,8 mm. For thinner panels use must be made of packing washers.

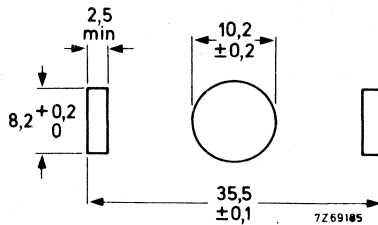

Fig. 2.

TECHNICAL DATA

Unless otherwise specified, all values have been determined at an ambient temperature of 15 to 35 °C, at atmospheric pressure of 960 to 1060 mbar and a relative humidity of 45 to 75%.

For measuring methods, see IEC publications 190 and 68. For the terms used, the paragraph "Glossary of terms" should be consulted.

Nominal resistance values (R_n) and tolerances	470 k Ω , $\pm 20\%$ 2,7 M Ω , $\pm 20\%$ 10 M Ω , -10% , $+40\%$
Resistance law	linear
Terminal resistance	$\leq 0,1\%$ of R_n
Contact resistance	$\leq 3\%$ of R_n
Insulation resistance	$> 10^5$ M Ω
Maximum dissipation at 40 °C	1 W
Limiting slider current at 40 °C, nominal resistance 470 k Ω 2,7 M Ω 10 M Ω	1,45 mA 0,61 mA 0,32 mA
Maximum voltage at 40 °C	1500 V d.c., provided that the maximum dissipation is not exceeded
Test voltage for 1 min between interconnected terminals and chassis	10 000 V, 50 Hz
Operating temperature range	-10 to $+70$ °C
Climatic category (IEC 68)	10/070/21

Operating torque	3 to 20 mNm
Permissible end stop torque	≤ 800 mNm
Permissible axial spindle load	≤ 100 N
Effective angle of rotation	250 - 265°
Mechanical angle of rotation	$300 \pm 5^\circ$

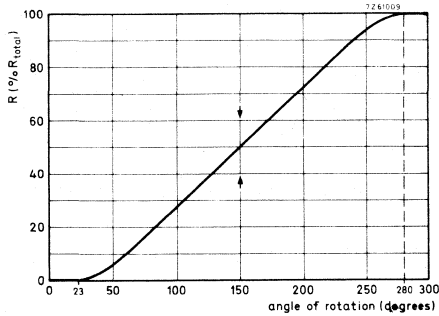

Fig. 3. Resistance as a function of the angle of rotation.

CATALOGUE NUMBERS FOR ORDERING

nominal resistance	catalogue number
470 k Ω	2322 460 90009
10 M Ω	2322 460 90011
2,7 M Ω	2322 460 90012

For ordering purposes please quote the catalogue numbers.

FOCUS POTENTIOMETER UNITS

- For low-bi colour picture tubes*, focusing voltage approx. 4,5 kV
- In conjunction with triplers or 4 diode-split line output transformers

QUICK REFERENCE DATA

	2322 460 90016	2322 460 90018	2322 460 90022
Nominal resistance	24 M Ω \pm 20%	59 M Ω \pm 20%	24 M Ω \pm 10%
Maximum dissipation at 70 °C	3,8 W	3,8 W	3,8 W
Climatic category, IEC 68	20/070/21	20/070/21	20/070/21

APPLICATION

These focus potentiometer units have been developed for adjustment of the focusing voltage for low-bi colour picture tubes.

DESCRIPTION

The potentiometer units comprise three resistance elements, which are connected in series. The centre element is provided with a slider (see also Fig. 1). The resistance elements are of the thick-film type; they are attached to a non-conductive temperature-resistant base (Al₂O₃, 96%). The housing of the potentiometer units is of grey, self-extinguishing, glass-fibre-filled thermoplastic material.

The units 2322 460 90016 and 2322 460 90022 are provided with snap-in clasps for mounting; unit 2322 460 90018 is suited for direct mounting e.g. to a tripler unit.

Fig. 1.

- a = focus output voltage of tripler unit;
- b = focusing voltage;
- c = earth.

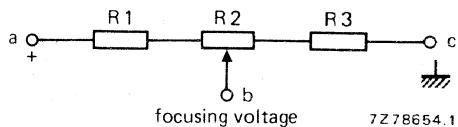

* Focus potentiometer units for hi-bi colour picture tubes are supplied under catalogue numbers 2322 460 90027, 2322 460 90028 and 2322 460 90029; see the relevant data sheet.

2322 460 90016
 2322 460 90018
 2322 460 90022

MFU50
 MFU46
 MFU50

OUTLINES

Dimensions in mm

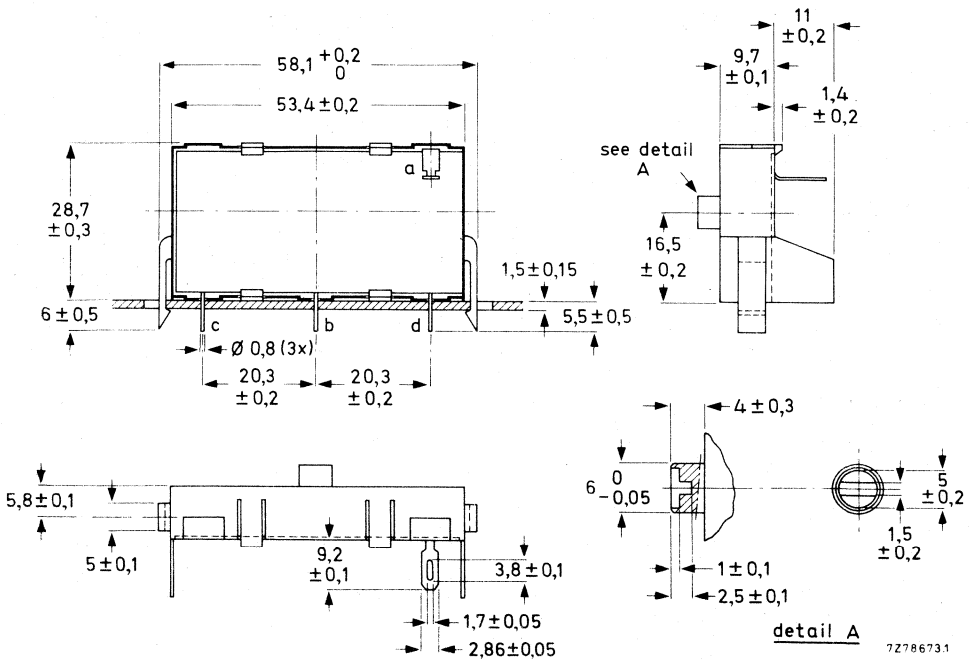

Fig. 2 Potentiometer unit 2322 460 90016. The indication of the terminals corresponds to those shown in Fig. 1; terminal d serves for mechanical fitting of the unit. Solder tag a fits Faston receptacles (2,8 x 0,5).

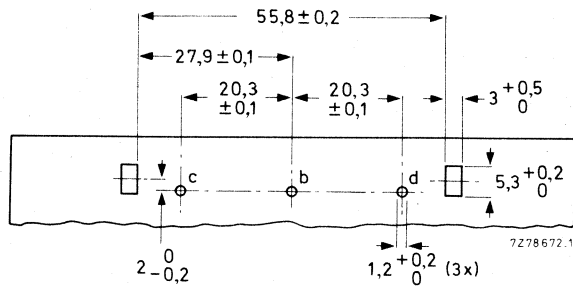

Fig. 3 Piercing diagram for board mounting of potentiometer unit 2322 460 90016 (component side).

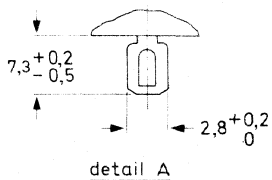
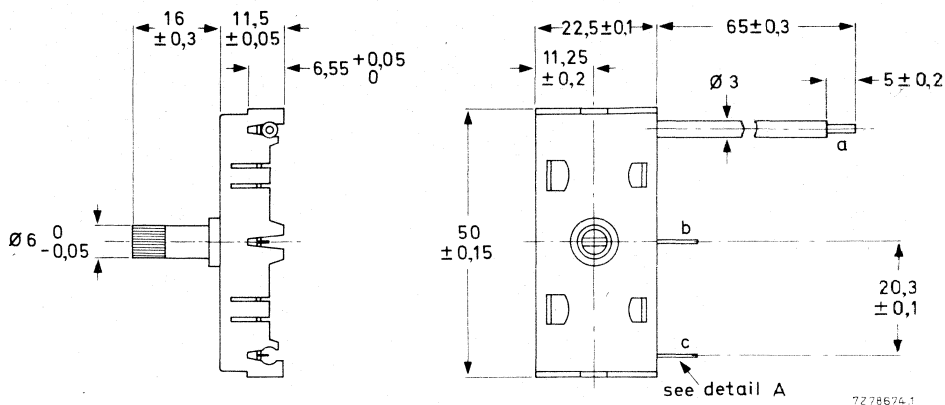

Fig. 4 Potentiometer unit **2322 460 90018**. The indication of the terminals corresponds to those shown in Fig. 1.

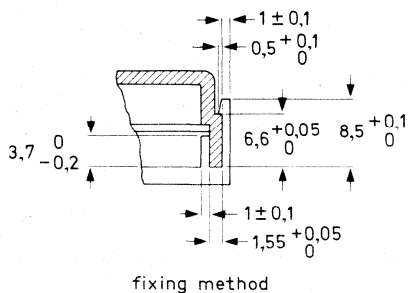

Fig. 5 Method of fixing potentiometer unit **2322 460 90018** e.g. to a tripler unit BG 1897-541.

2322 460 90016
 2322 460 90018
 2322 460 90022

MFU50
 MFU46
 MFU50

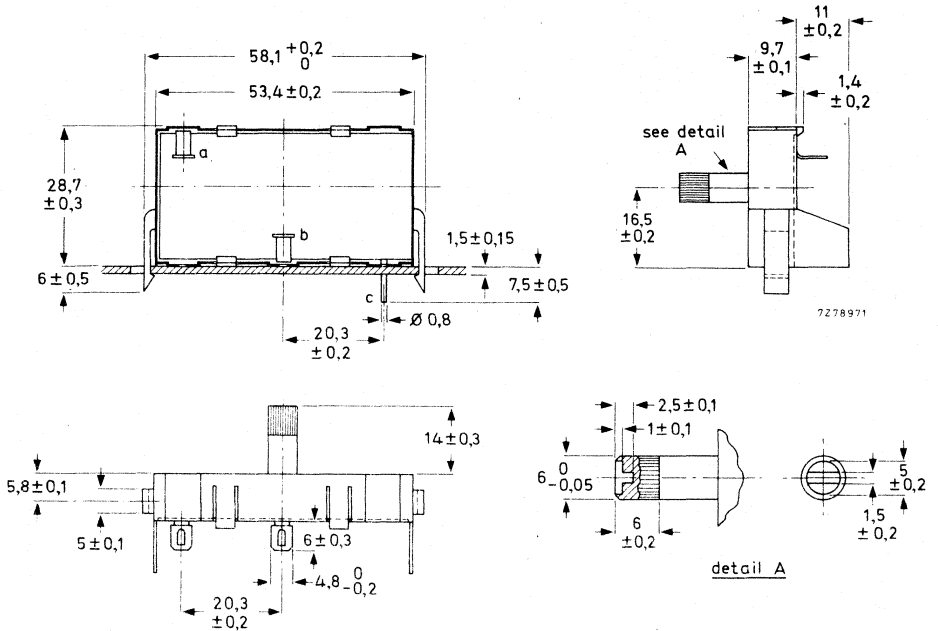

Fig. 6 Potentiometer unit 2322 460 90022. The indication of the terminals corresponds to those shown in Fig. 1. The solder tags fit on Faston receptacles (4,8 x 0,5).

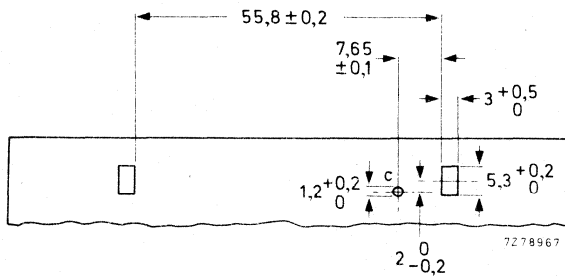

Fig. 7 Piercing diagram for board mounting of potentiometer unit 2322 460 90022 (component side).

TECHNICAL DATA

	2322 460		
	90016	90018	90022
Nominal resistance value (R1 + R2 + R3, Fig. 1)	24 M Ω	59 M Ω	24 M Ω
Tolerance on nominal resistance	$\pm 20\%$	$\pm 20\%$	$\pm 10\%^*$
Resistance ratio at 25 °C (focusing voltage range)			
$\frac{R3 + R2}{R_{tot}}$	$\geq 0,73$	$\geq 0,65$	$\geq 0,73$
$\frac{R3}{R_{tot}}$	$\leq 0,50$	$\leq 0,42$	$\leq 0,50$
Variation in resistance ratios at 70 °C	$\leq 3\%$	$\leq 3\%$	$\leq 3\%$
Resistance law of R2	linear	linear	linear
Contact resistance	≤ 250 k Ω	≤ 600 k Ω	≤ 250 k Ω
Maximum dissipation at 70 °C	3,8 W	3,8 W	3,8 W
Limiting element voltage	8,5 kV	8,5 kV	8,5 kV
Insulation resistance between interconnected terminals and mounting base at 500 V (d.c.)	$> 10^3$ M Ω	$> 10^3$ M Ω	$> 10^3$ M Ω
Test voltage between interconnected terminals and mounting base for 1 min	10 kV	10 kV	10 kV
Operation temperature range	-20 to +70 °C	-20 to +70 °C	-20 to +70 °C
Climatic category, IEC 68	20/070/21	20/070/21	20/070/21
Operating torque	3,5 to 30 mNm	3,5 to 30 mNm	3,5 to 30 mNm
Permissible end stop torque	≤ 800 mNm	≤ 800 mNm	≤ 800 mNm
Permissible axial spindle load	≤ 12 N	≤ 12 N	≤ 12 N

Note

Potentiometer units with different resistance values and resistance ratios, connecting terminals and spindles are available on request.

MARKING

The potentiometer units are marked with last five digits of the catalogue number, and period and year of manufacture.

* The $\pm 10\%$ tolerance allows the possibility of applying a V_{g2} adjustment, with a total resistance of e.g. 2,7 M Ω , between terminal c and earth; as a result the resistance ratios become $\geq 0,75$ and $\leq 0,55$ respectively.

2322 460 90016
 2322 460 90018
 2322 460 90022

MFU50
 MFU46
 MFU50

TESTS AND REQUIREMENTS

IEC 68-2 test method	name of test	procedure (quick reference)	requirements
Ta	Soldering	Solder bath, non-activated colophony flux, solder temp. 235 °C, dwell time 2 s.	Good tinning.
Na	Rapid change of temperature	5 cycles of ½ h at -20 °C and ½ h at +70 °C.	No damage; R_{tot} and resistance ratios shall be within tolerance limits.
	Vibration	50 Hz, 1 mm, 3 directions, 2 h per direction.	
	Dry heat	16 h at +70 °C, no voltage applied. Reconditioning 2 h.	
	Cold	16 h at -20 °C; no voltage applied; 2 h reconditioning.	
	Rotational life	50 cycles at a rate of 10 cycles/min, no voltage applied.	
	Endurance	1000 h at 70 °C, 9 kV (d.c.) applied; slider adjusted to 5 kV with respect to earth.	Stability of preset voltage \leq 0,5%.
	Humidity	21 days at 40 °C, R. H. 93%; 650 V (d.c.) applied.	contact resistance and insulation resistance shall meet initial requirements.
	Resistance ratios	4 h at 70 °C, 9 kV (d.c.) applied; slider adjusted to 5 kV with respect to earth at 25 °C.	variation of resistance ratios \leq 3%.

FOCUS POTENTIOMETER UNITS

- For hi-bi colour picture tubes*, focusing voltage approx. 7 kV
- In conjunction with diode-split line output transformers or triplers with or without 25 kV bleeder resistor

QUICK REFERENCE DATA

	2322 460 90027	2322 460 90028	2322 460 90029
Nominal resistance	24 M Ω \pm 10%	83 M Ω \pm 15%	83 M Ω \pm 15%
Maximum dissipation at 70 °C	3,8 W	3,8 W	3,8 W
Climatic category, IEC 68	20/070/21	20/070/21	20/070/21

APPLICATION

These focus potentiometer units have been developed for adjustment of the focusing voltage for hi-bi colour picture tubes.

DESCRIPTION

The potentiometer units comprise three resistance elements, which are connected in series. The centre element is provided with a slider (see also Figs 2, 4 and 6). The resistance elements are of the thick-film type; they are attached to a non-conductive temperature-resistant base (Al₂O₃, 96%).

Potentiometer unit 2322 460 90027 is designed for an input voltage of 8,3 kV; the units 2322 460 90028 and 2322 460 90029 are designed for applications with a 25 kV bleeder resistor. To obtain better stability of the focusing voltage, unit 2322 460 90028 is, moreover, provided with a tap for connection to the 6,25 kV tap of a 4-diode-split line output transformer (e.g. AT2076/30); unit 2322 460 90029 has a similar tap for connection to the 8,3 kV tap of a tripler or a 3-diode-split line output transformer (e.g. AT2076/51).

The housing of the potentiometer units is of grey, self-extinguishing, glass-fibre-filled thermoplastic material.

The units are provided with snap-in clasps for mounting.

* Focus potentiometer units for low-bi colour picture tubes are supplied under catalogue numbers 2322 460 90016, 2322 460 90018 and 2322 460 90022; see the relevant data sheet.

2322 460 90027
 2322 460 90028
 2322 460 90029

MFU50

OUTLINES

Dimensions in mm

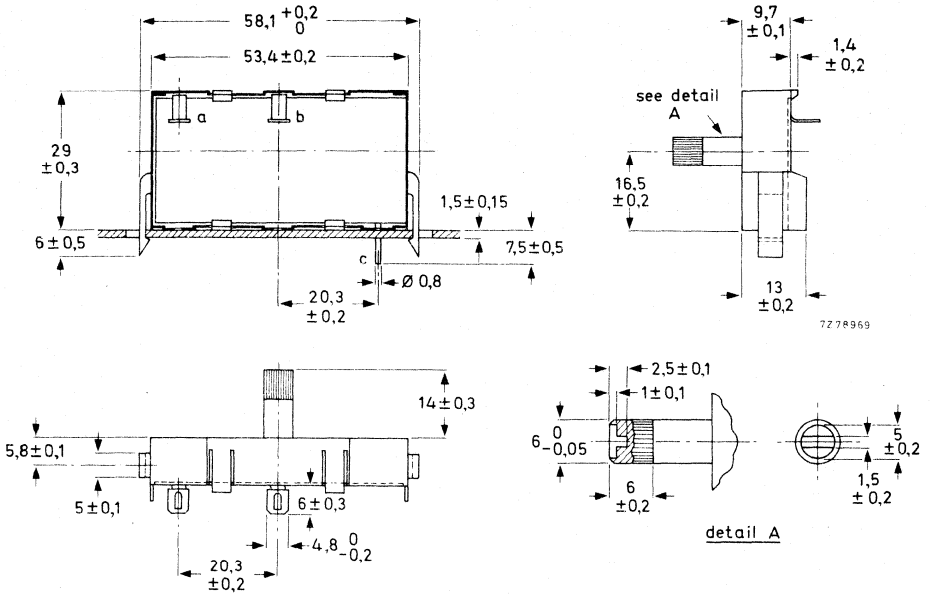

Fig. 1 Potentiometer unit 2322 460 90027. The indication of the terminals corresponds to those shown in Fig. 2. The solder tags fit on Faston receptacles (4,8 x 0,5).

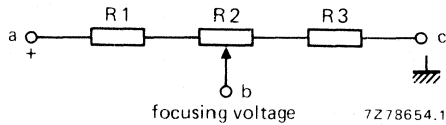

Fig. 2 Diagram of potentiometer unit 2322 460 90027.

- a = focus output voltage of e.h.t. device (8,3 kV);
- b = focusing voltage;
- c = earth.

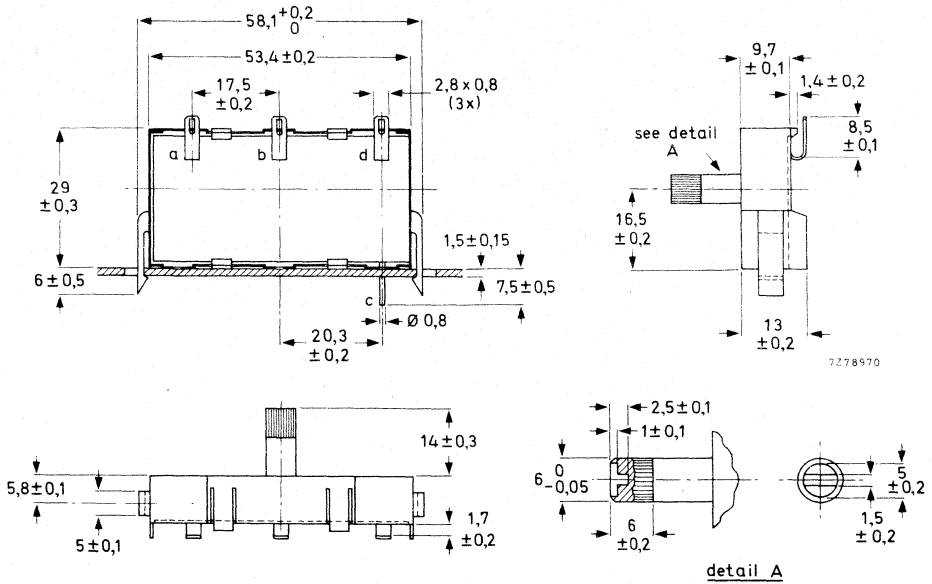

Fig. 3 Potentiometer unit **2322 460 90028**. The indication of the terminals corresponds to those shown in Fig. 4. The solder tags fit on Faston receptacles (2,8 x 0,8).

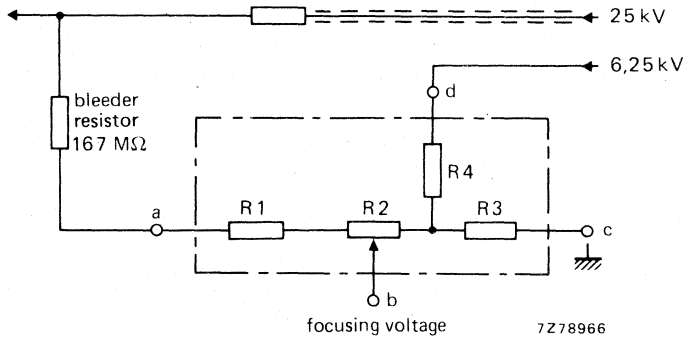

Fig. 4 Diagram of potentiometer unit **2322 460 90028**.

- a = e.h.t. voltage via bleeder resistor;
- b = focusing voltage;
- c = earth;
- d = 6,25 kV connection.

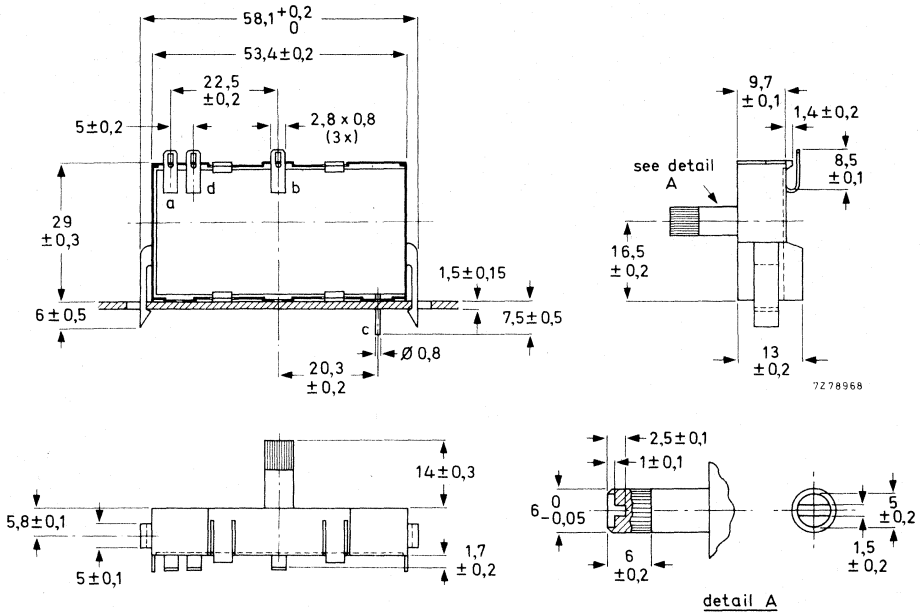

Fig. 5 Potentiometer unit 2322 460 90029. The indication of the terminals corresponds to those shown in Fig. 6. The solder tags fit on Faston receptacles (2,8 x 0,8).

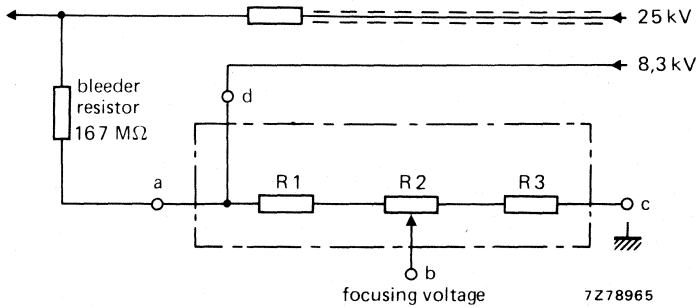

Fig. 6 Diagram of potentiometer unit 2322 460 90029.

- a = e.h.t. voltage via bleeder resistor;
- b = focusing voltage;
- c = earth;
- d = 8,3 kV connection.

TECHNICAL DATA

2322 460

	90027	90028	90029
Nominal resistance value (R1 + R2 + R3, Figs 2, 4 and 6)	24 M Ω	83 M Ω	83 M Ω
Tolerance on nominal resistance	$\pm 10\%$ *	$\pm 15\%$	$\pm 15\%$
Resistance ratio at 25 °C (focusing voltage range)			
$\frac{R_3 + R_2}{R_{tot}}$	$\geq 0,94$ (max. 0,98)	$\geq 0,94$ (max. 0,98)	$\geq 0,94$ (max. 0,98)
$\frac{R_3}{R_{tot}}$	$\leq 0,75$	$\leq 0,75$	$\leq 0,75$
Variation in resistance ratios at 70 °C	$\leq 3\%$	$\leq 3\%$	$\leq 3\%$
Resistance law of R2	linear	linear	linear
Contact resistance	≤ 350 k Ω	≤ 750 k Ω	≤ 750 k Ω
Maximum dissipation at 70 °C	3,8 W	3,8 W	3,8 W
Limiting element voltage	9 kV	10 kV	10 kV
Insulation resistance between interconnected terminals and mounting base at 500 V (d.c.)	$> 10^3$ M Ω	$> 10^3$ M Ω	$> 10^3$ M Ω
Test voltage between interconnected terminals and mounting base for 1 min	10 kV	15 kV	15 kV
Operation temperature range	-20 to +70 °C	-20 to +70 °C	-20 to +70 °C
Climatic category, IEC 68	20/070/21	20/070/21	20/070/21
Operating torque	3,5 to 30 mNm	3,5 to 30 mNm	3,5 to 30 mNm
Permissible end stop torque	≤ 800 mNm	≤ 800 mNm	≤ 800 mNm
Permissible axial spindle load	≤ 12 N	≤ 12 N	≤ 12 N

Note

Potentiometer units with different resistance values and resistance ratios, connecting terminals and spindles are available on request.

MOUNTING

Fig. 7

Piercing diagram for board mounting (component side).

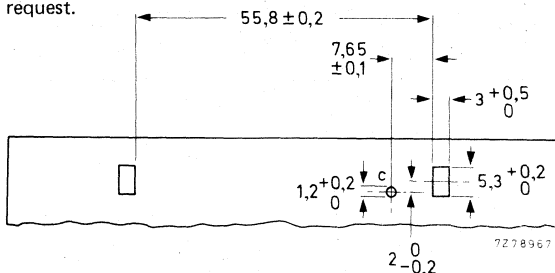

MARKING

The potentiometer units are marked with last five digits of the catalogue number, and period and year of manufacture.

* The $\pm 10\%$ tolerance allows the possibility of applying a V_{g2} adjustment, with a total resistance of e.g. 3,8 M Ω , between terminal c and earth; as a result the resistance ratio R_3/R_{tot} becomes $\leq 0,79$.

2322 460 90027
 2322 460 90028
 2322 460 90029

MFU50



TESTS AND REQUIREMENTS

IEC 68-2 test method	name of test	procedure (quick reference)	requirements
Ta	Soldering	Solder bath, non-activated colophony flux, solder temp. 235 °C, dwell time 2 s.	Good tinning.
Na	Rapid change of temperature	5 cycles of ½ h at -20 °C and ½ h at +70 °C.	
	Vibration	50 Hz, 1 mm, 3 directions, 2 h per direction.	
	Dry heat	16 h at +70 °C, no voltage applied. Reconditioning 2 h.	
	Cold	16 h at -20 °C; no voltage applied; 2 h reconditioning.	No damage; R _{rot} and resistance ratios shall be within tolerance limits.
	Rotational life	50 cycles at a rate of 10 cycles/min, no voltage applied.	
	Endurance	1000 h at 70 °C, 9 kV (d.c.) applied slider adjusted to 7 kV with respect to earth.	Stability of preset voltage ≤ 0,5%.
	Humidity	21 days at 40 °C, R.H. 93%, 650 V (d.c.) applied	contact resistance and insulation resistance shall meet initial requirements.
	Resistance ratios	4 h at 70 °C, 9 kV (d.c.) applied; slider adjusted to 7 kV with respect to earth at 25 °C.	variation of resistance ratios ≤ 3%.

10 mm CERMET PRESET POTENTIOMETERS

QUICK REFERENCE DATA

Resistance range (E6-series), linear law	100 Ω to 6,8 M Ω	←
Maximum dissipation at 70 °C	0,5 W	
Climatic category, IEC 68	55/125/56	←

APPLICATION

These potentiometers have been designed for preset resistance control with provision for re-adjustments. They are particularly suitable for use in professional apparatus and/or in those applications where stability is of extreme importance.

DESCRIPTION

These potentiometers comprise a resistance element of thick film, with particles of conductive metal dispersed in it. The element is supported by a non-conductive temperature-resistant ceramic base. The terminals a and c (see Figs 1 to 3) are connected to the ends of the resistance element; terminal b is connected to the slider.

The potentiometers are available in three versions: two for horizontal and one for vertical mounting on printed-wiring boards.

Outlines

Dimensions in mm

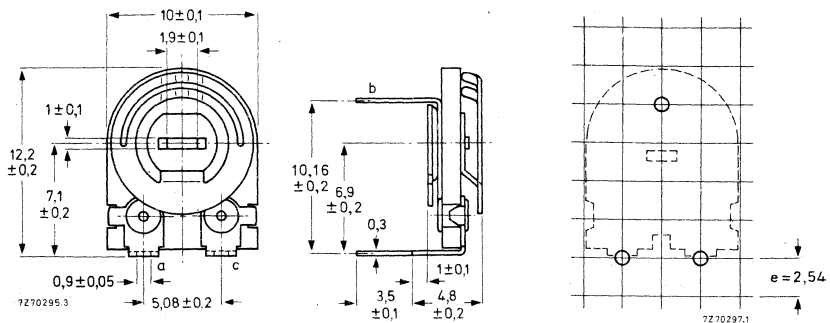

Fig. 1 Potentiometer for horizontal mounting, 2322 482 2

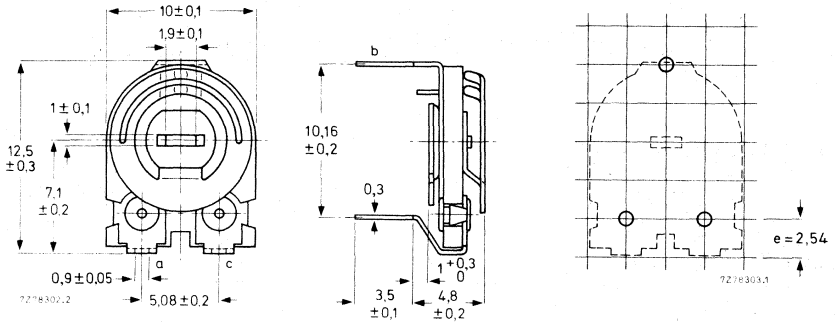

Fig. 2 Potentiometer for horizontal mounting, 2322 482 4

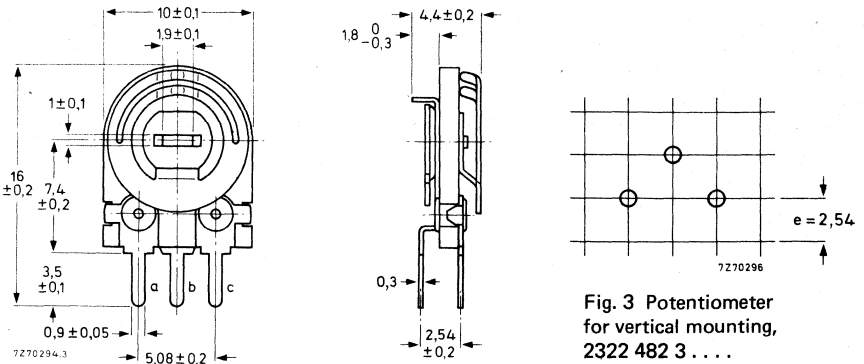

Fig. 3 Potentiometer for vertical mounting, 2322 482 3

TECHNICAL DATA

Unless stated otherwise, all electrical values have been determined at an ambient temperature of 15 to 35 °C, an air pressure of 860 to 1060 mbar and a relative humidity of 45 to 75%. For terms and test methods see IEC publication 393-1.

- ➔ Nominal resistance values (R_n) 100 Ω to 6,8 MΩ, see Table 1
- ➔ Tolerance on the nominal resistance ± 20% and ± 10%
- Resistance law and tolerances linear, see Fig. 4
- Terminal resistance ≤ 0,5% of R_{total} or 2 Ω, whichever is the greater
- ➔ Contact resistance variation (CRV) ≤ 0,5% of R_{total}
- Maximum dissipation (P_{max}) at 70 °C 0,5 W, see Fig. 5

Limiting voltage (d.c.)	250 V	
Limiting slider current	$\sqrt{\left(\frac{P_{max}}{R_{total}}\right)}$	
Operating temperature range	-55 to +125 °C	←
Temperature coefficient		
$R_n \leq 1 M\Omega$	± 50 ppm/°C	←
$R_n > 1 M\Omega$	± 100 ppm/°C	←
Operating torque	4 to 30 mNm	
Permissible end stop torque	≤ 50 mNm	
Effective angle of rotation	$220 \pm 5^\circ$	
Mechanical angle of rotation	$235 \pm 5^\circ$	
Rotational life	200 cycles	←
Settability	1°/oo of R_{total} within 10 s	←
Mass	approx. 1,5 g	

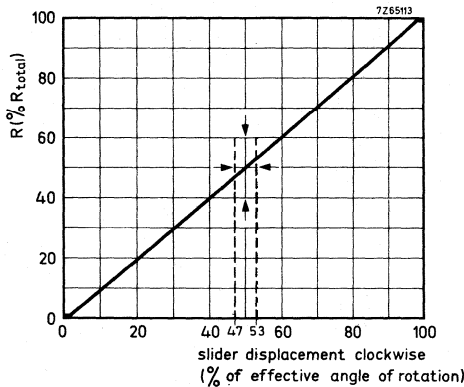

Fig. 4 Linear resistance law.

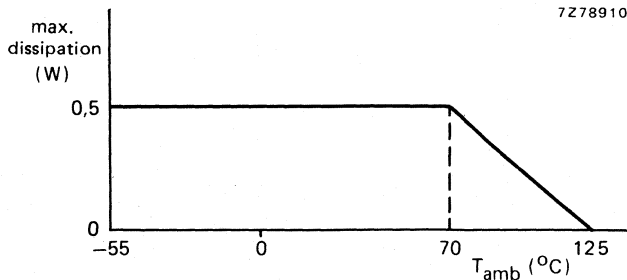

Fig. 5 Maximum dissipation as a function of ambient temperature.

→ COMPOSITION OF THE CATALOGUE NUMBER

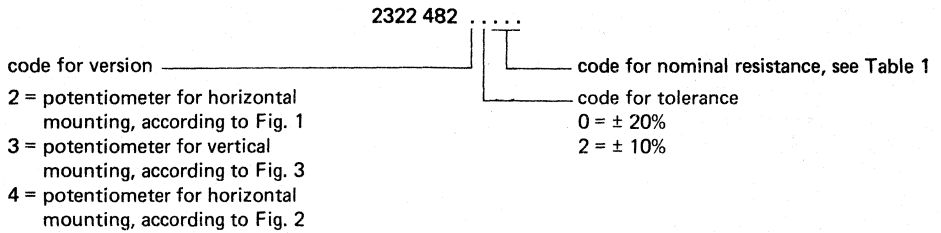

Table 1

nominal resistance	code in cat. number	nominal resistance	code in cat. number
100 Ω	101	33 kΩ	333
150 Ω	151	47 kΩ	473
220 Ω	221	68 kΩ	683
330 Ω	331	100 kΩ	104
470 Ω	471	150 kΩ	154
680 Ω	681	220 kΩ	224
1 kΩ	102	330 kΩ	334
1,5 kΩ	152	470 kΩ	474
2,2 kΩ	222	680 kΩ	684
3,3 kΩ	332	1 MΩ	105
4,7 kΩ	472	1,5 MΩ	155
6,8 kΩ	682	2,2 MΩ	225
10 kΩ	103	3,3 MΩ	335
15 kΩ	153	4,7 MΩ	475
22 kΩ	223	6,8 MΩ	685

TESTS AND REQUIREMENTS

IEC 393-1 clause	IEC 68-2 test method	name of test	procedure (quick reference)	requirements
6.22.3	Ta	Soldering	Solder bath: 230 ± 10 °C, 2 ± 0,5 s.	Good tinning.
6.22.4	Tb (method 1B)	Resistance to soldering heat	Solder bath: 350 ± 10 °C, 3,5 ± 0,5 s.	$\Delta R_{ac}/R_{ac} \leq 0,1\%$
6.23	Na	Rapid change of temperature	5 cycles of ½ h at -55 °C and ½ h at +125 °C.	$\Delta R_{ac}/R_{ac} \leq 0,5\%$; $\Delta V_{ab}/V_{ac} \leq 0,1\%$
6.24	Fc	Vibration	10 to 500 Hz, 0,75 mm or 10 g (whichever is the less), 3 directions, 2 h per direction.	$\Delta R_{ac}/R_{ac} \leq 0,1\%$; $\Delta V_{ab}/V_{ac} \leq 0,2\%$
6.25	E6	Bumping	40 g, 4000 bumps	$\Delta R_{ac}/R_{ac} \leq 0,1\%$.





IEC 393-1 clause	IEC 68-2 test method	name of test	procedure (quick reference)	requirements
6.26.2 6.26.3 6.26.4 6.26.6	Ba	Dry heat	16 h at 70 ± 2 °C.	
	Db	Damp heat, cyclic	1 cycle of 24 h, 55 ± 2 °C, R.H. 95 to 100%.	
	Aa	Cold	2 h at -55 ± 3 °C.	
	Db	Damp heat, cyclic	5 cycles of 24 h, 55 ± 2 °C, R.H. 95 to 100%.	
			Final measurement	$\Delta R_{ac}/R_{ac} \leq 0,5\%$; starting torque ≤ 36 mNm.
6.30		Electrical endurance	1000 h at 70 °C, cyclic (1,5 h on, 0,5 h off; slider at 0,67 a - c). Load between a and c (0,5 W).	$\Delta R_{ac}/R_{ac} \leq 1\%$ $\Delta V_{ab}/V_{ac} \leq 0,2\%$
			1000 h at 70 °C, cyclic (1,5 h on, 0,5 h off; slider at 0,67 a - c). Load between a and b (0,33 W).	$\Delta R_{ab}/R_{ab} \leq 3\%$
6.29		Mechanical endurance	200 cycles, 4 cycles/min., no load.	$\Delta R_{ac}/R_{ac} \leq 2\%$; CRV $\leq 0,5\%$ of R_{Total} .

Climatic sequence

IEC 393-1 clause	IEC 68-2 test method	name of test	procedure (quick reference)	requirements
6.27	Ca	Damp heat, steady state	Slider at 0,67 a - c, no load; 56 days.	$CRV \leq 0,5\%$ of R_{total} . $\Delta R_{ac}/R_{ac} \leq 0,5\%$; $\Delta R_{ab}/R_{ab} \leq 1\%$; $\Delta V_{ab}/V_{ac} \leq 0,2\%$.
			Slider at 0,67 a - c, load between a and c (0,05 W).	$\Delta R_{ac}/R_{ac} \leq 0,5\%$; $\Delta V_{ab}/V_{ac} \leq 0,2\%$.
			Slider at 0,67 a - c, load between a and b (0,03 W).	$\Delta R_{ab}/R_{ab} \leq 2\%$.
		Immersion in cleaning solvents	Immersion in boiling mixture of 1.1.2. trichlorotrifluoroethane and isopropanol (75%/25%) for $5 \pm 0,5$ min., followed by 5 min drying (rubbing or wrapping excluded).	Marking legible, no damage. $\Delta R_{ac}/R_{ac} \leq 0,5\%$; $CRV \leq 0,5\%$; operating torque: 2 to 10 mNm.



TEST SWITCHES



TEST SWITCHES

APPLICATION

These switches are designed to simplify the testing of any electronic circuit by providing a swift means of changing over from "normal working" to "test" conditions. They are often used for testing a particular section of a circuit immediately after set assembly or later during service.

DESCRIPTION

Three types of switch are available designed for mounting on printed-wiring boards. All types can be supplied for horizontal or vertical mounting. ←

The basic switch consists of a rotatable selector contact and two or three switch connections, mounted on an insulating plate. By turning the selector contact one of the switch connections can be connected to the centre contact. The contacts are of the "break before make" type.

One switch type is provided with two active switch connections and a "centre-off" position. The second type has three active switch connections; the third type has two active switch connections (without "centre-off" position).

Switches are available for screwdriver-control (allowing the "flatness" of printed-wiring circuitry to be maintained), or finger-control by means of a plastic knob.



OUTLINES

Dimensions in mm

Fig. 1 Test switch for horizontal mounting, with two active switch connections:
 a. with "centre-off" position,
 b. without "centre-off" position,
 c. hole pattern for mounting on a printed-wiring board (solder side).

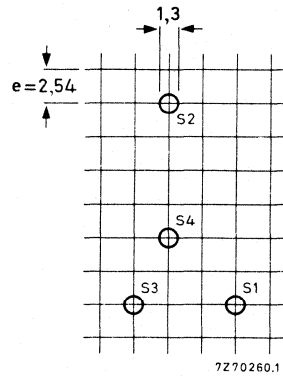
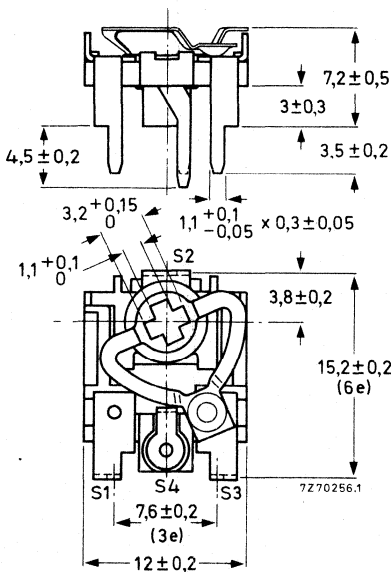
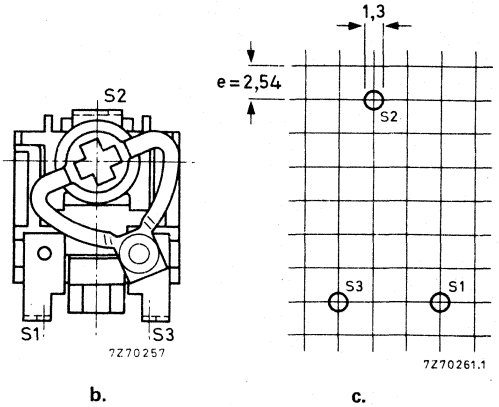
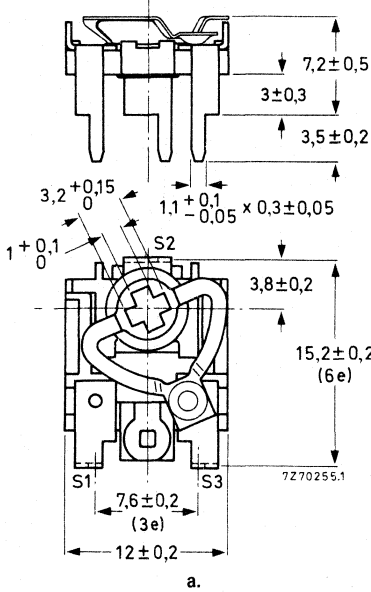

Fig. 2a Test switch for horizontal mounting, with three active switch connections.

Fig. 2b Hole pattern for mounting on a printed-wiring board (solder side).

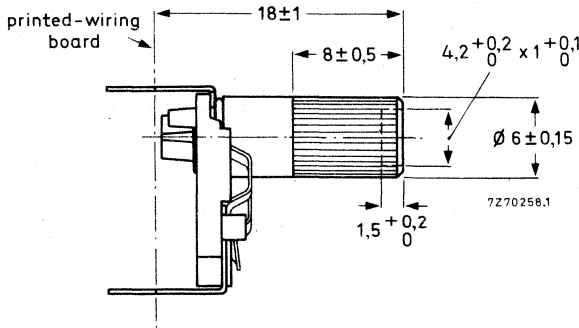

Fig. 3 Test switch for horizontal mounting with adjustment knob at the side of the selector contact.

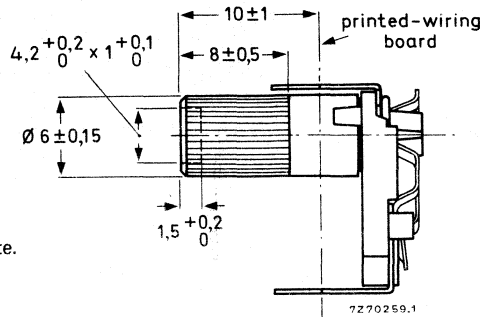
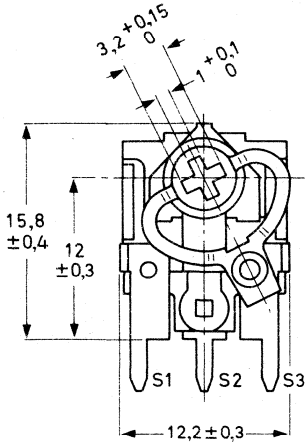
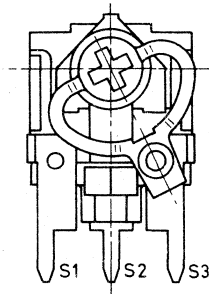

Fig. 4 Test switch for horizontal mounting with adjustment knob at the side of the base plate.



a.



b.

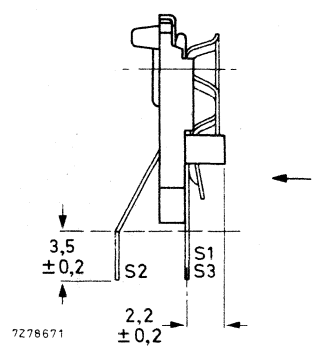

c.

Fig. 5 Test switch for vertical mounting, with two active switch connections;
 a. with "centre-off" position,
 b. without "centre-off" position,
 c. hole pattern for mounting on a printed-wiring board (solder side).

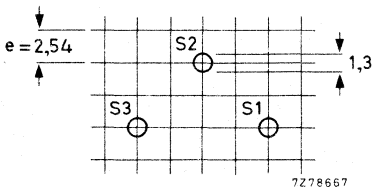

7278667

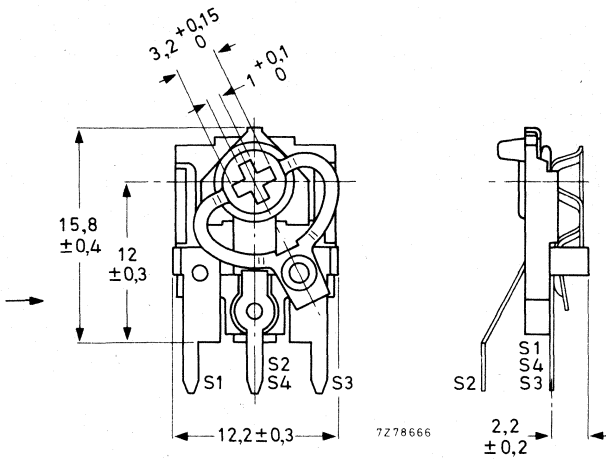

Fig. 6a Test switch for vertical mounting, with three active switch conditions.

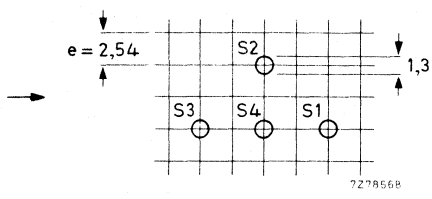

Fig. 6b Hole pattern for mounting on a printed-wiring board (solder side).

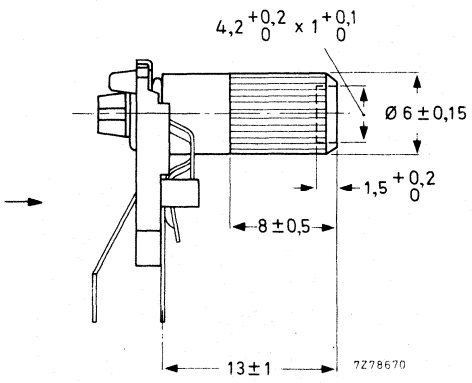

Fig. 7 Test switch for vertical mounting with adjustment knob at the side of the selector contact.

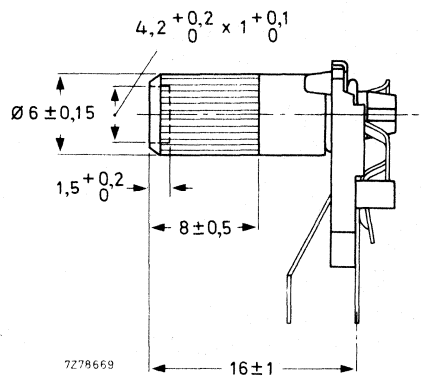
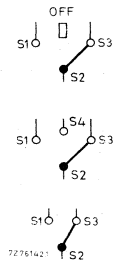
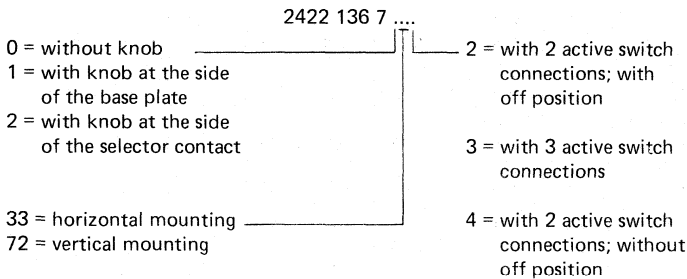

Fig. 8 Test switch for vertical mounting, with adjustment knob at the side of the base plate.

TECHNICAL DATA

Contact resistance	
initially	≤ 20 mΩ
after 50 switching operations at ≤ 10 mA, ≤ 500 V	≤ 200 mΩ
Operating torque	5 to 50 mNm
End stop torque	≤ 100 mNm
Life	≥ 50 switching operations
Mass	
switch without knob	approx. 1 g
switch with knob	approx. 1,5 g

COMPOSITION OF THE CATALOGUE NUMBER



STANDARD SERIES OF VALUES IN A DECADE for resistances and capacitances

according to I. E. C. publication 63

E192	E96	E48	E192	E96	E48	E192	E96	E48	E192	E96	E48	E192	E96	E48
100	100	100	169	169	169	284			481			816		
101			172			287	287	287	487	487	487	825	825	825
102	102		174	174		291			493			835		
104			176			294	294		499	499		845	845	
105	105	105	178	178	178	298			505			856		
106			180			301	301	301	511	511	511	866	866	866
107	107		182	182		305			517			876		
109			184			309	309		523	523		887	887	
110	110	110	187	187	187	312			530			898		
111			189			316	316	316	536	536	536	909	909	909
113	113		191	191		320			542			920		
114			193			324	324		549	549		931	931	
115	115	115	196	196	196	328			556			942		
117			198			332	332	332	562	562	562	953	953	953
118	118		200	200		336			569			965		
120			203			340	340		576	576		976	976	
121	121	121	205	205	205	344			583			988		
123			208			348	348	348	590	590	590			
124	124		210	210		352			597					
126			213			357	357		604	604				
127	127	127	215	215	215	361			612			10	10	10
129			218			365	365	365	619	619	619	11		
130	130					370			626			12	12	
132			221	221		374	374		634	634		13		
133	133	133	223			379			642			15	15	15
135			226	226	226	383	383	383	649	649	649	16		
137	137		229			388			657			18	18	
138			232	232		392	392		665	665		20		
140	140	140	234			397			673			22	22	22
142			237	237	237	402	402	402	681	681	681	24		
143	143		240			407			690			27	27	
145			243	243		412	412		698	698		30		
147	147	147	246			417			706			33	33	33
149			249	249	249	422	422	422	715	715	715	36		
150	150		252			427			723			39	39	
152			255	255		432	432		732	732		43		
154	154	154	258			437			741			47	47	47
156			261	261	261	442	442	442	750	750	750	51		
158	158		264			448			759			56	56	
160			267	267		453	453		768	768		62		
162	162	162	271			459			777			68	68	68
164			274	274	274	464	464	464	787	787	787	75		
165	165		277			470			796			82	82	
167			280	280		475	475		806	806		91		



Contents

		page
DATA HANDBOOK SYSTEM		
VARIABLE RESISTORS		
Wirewound potentiometers	2322 003	
	2322 010	3
Wirewound potentiometers	2322 004	9
Wirewound preset potentiometers	2322 011	13
Wirewound potentiometers	2322 012	
	2322 013	17
Wirewound potentiometers	2322 018	23
Wirewound potentiometers	2322 020	29
Load potentiometers	2322 095-	
	2322 097	35
Carbon potentiometers, introduction		43
Carbon control potentiometers	CP16-series	49
	CP23-series	65
Carbon preset potentiometers	2322 409	83
	2322 410	91
	2322 411	97
Multiturn carbon preset potentiometers	2322 412	
	2322 413	
	2322 414	105
Slide carbon potentiometers	2322 415	117
	2322 42.	125
	2322 43.	137
Miniature carbon potentiometers	2322 440	151
Carbon potentiometers for tv focus trimming	2322 460 90009	
	2322 460 90011	
	2322 460 90012	153
Focus potentiometer units	2322 460 90016	
	2322 460 90018	
	2322 460 90022	157
Focus potentiometer units	2322 460 90027	
	2322 460 90028	
	2322 460 90029	163
Cermet preset potentiometers	2322 482	169
TEST SWITCHES	2422 136 7....	179
STANDARD SERIES OF VALUES IN A DECADE		



VARIABLE RESISTORS AND TEST SWITCHES



VARIABLE RESISTORS

TEST SWITCHES

CONTENTS

Argentina: FAPESA I.y.C., Av. Crovara 2550, Tablada, Prov. de BUENOS AIRES, Tel. 652-7438/7478.

Australia: PHILIPS INDUSTRIES HOLDINGS LTD., Elcoma Division, 67 Mars Road, LANE COVE, 2066, N.S.W., Tel. 427 08 88.

Austria: ÖSTERREICHISCHE PHILIPS BAUELEMENTE Industrie G.m.b.H., Triester Str. 64, A-1101 WIEN, Tel. 62 91 11.

Belgium: M.B.L.E., 80, rue des Deux Gares, B-1070 BRUXELLES, Tel. 523 00 00.

Brazil: IBRAPE, Caixa Postal 7383, Av. Brigadeiro Faria Lima, 1735 SAO PAULO, SP, Tel. (011) 211-2600.

Canada: PHILIPS ELECTRONICS LTD., Electron Devices Div., 601 Milner Ave., SCARBOROUGH, Ontario, M1B 1M8, Tel. 292-5161.

Chile: PHILIPS CHILENA S.A., Av. Santa Maria 0760, SANTIAGO, Tel. 39-40 01.

Colombia: SADAPE S.A., P.O. Box 9805, Calle 13, No. 51 + 39, BOGOTA D.E. 1., Tel. 600 600.

Denmark: MINIWATT A/S, Emdrupvej 115A, DK-2400 KØBENHAVN NV., Tel. (01) 69 16 22.

Finland: OY PHILIPS AB, Elcoma Division, Kaivokatu 8, SF-00100 HELSINKI 10, Tel. 1 72 71.

France: R.T.C. LA RADIOELECTRIQUE-COMPELEC, 130 Avenue Ledru Rollin, F-75540 PARIS 11, Tel. 355-44-99.

Germany: VALVO, UB Bauelemente der Philips G.m.b.H., Valvo Haus, Burchardstrasse 19, D-2 HAMBURG 1, Tel. (040) 3296-1.

Greece: PHILIPS S.A. HELLENIQUE, Elcoma Division, 52, Av. Syngrou, ATHENS, Tel. 915 311.

Hong Kong: PHILIPS HONG KONG LTD., Elcoma Div., 15/F Phiips Ind. Bldg., 24-28 Kung Yip St., KWAI CHUNG, Tel. NT 24 51 21.

India: PEICO ELECTRONICS & ELECTRICALS LTD., Band Box House, 254-D, Dr. Annie Besant Rd., Prabhadevi, BOMBAY-25-DD, Tel. 457 311-5.

Indonesia: P.T. PHILIPS-RALIN ELECTRONICS, Elcoma Division, 'Timah' Building, Jl. Jen. Gatot Subroto, P.O. Box 220, JAKARTA, Tel. 44 163.

Ireland: PHILIPS ELECTRICAL (IRELAND) LTD., Newstead, Clonskeagh, DUBLIN 14, Tel. 69 33 55.

Italy: PHILIPS S.p.A., Sezione Elcoma, Piazza IV Novembre 3, I-20124 MILANO, Tel. 2-6994.

Japan: NIHON PHILIPS CORP., Shuwa Shinagawa Bldg., 26-33 Takanawa 3-chome, Minato-ku, TOKYO (108), Tel. 448-5611.
(IC Products) SIGNETICS JAPAN, LTD, TOKYO, Tel. (03)230-1521.

Korea: PHILIPS ELECTRONICS (KOREA) LTD., Elcoma Div., Philips House, 260-199 Itaewon-dong, Yongsan-ku, C.P.O. Box 3680, SEOUL, Tel. 794-4202.

Malaysia: PHILIPS MALAYSIA SDN. BERHAD, Lot 2, Jalan 222, Section 14, Petaling Jaya, P.O.B. 2163, KUALA LUMPUR, Selangor, Tel. 77 44 11.

Mexico: ELECTRONICA S.A. de C.V., Varsovia No. 36, MEXICO 6, D.F., Tel. 533-11-80.

Netherlands: PHILIPS NEDERLAND B.V., Afd. Elonco, Boschdijk 525, 5600 PB EINDHOVEN, Tel. (040) 79 33 33.

New Zealand: PHILIPS ELECTRICAL IND. LTD., Elcoma Division, 2 Wagener Place, St. Lukes, AUCKLAND, Tel. 867 119.

Norway: NORSK A/S PHILIPS, Electronica, Sørkedalsveien 6, OSLO 3, Tel. 46 38 90.

Peru: CADESA, Rocca de Vergallo 247, LIMA 17, Tel. 62 85 99.

Philippines: PHILIPS INDUSTRIAL DEV. INC., 2246 Pasonong Tamo, P.O. Box 911, Makati Comm. Centre, MAKATI-RIZAL 3116, Tel. 86-89-51 to 59.

Portugal: PHILIPS PORTUGESA S.A.R.L., Av. Eng. Duharte Pacheco 6, LISBOA 1, Tel. 68 31 21.

Singapore: PHILIPS PROJECT DEV. (Singapore) PTE LTD., Elcoma Div., P.O.B. 340, Toa Payoh CPO, Lorong 1, Toa Payoh, SINGAPORE 12, Tel. 53 88 11.

South Africa: EDAC (Pty.) Ltd., 3rd Floor Rainer House, Upper Railway Rd. & Ove St., New Doornfontein, JOHANNESBURG 2001, Tel. 614-2362/9.

Spain: COPRESA S.A., Balmes 22, BARCELONA 7, Tel. 301 63 12.

Sweden: A.B. ELCOMA, Lidingsvägen 50, S-115 84 STOCKHOLM 27, Tel. 08/67 97 80.

Switzerland: PHILIPS A.G., Elcoma Dept., Allmendstrasse 140-142, CH-8027 ZÜRICH, Tel. 01/43 22 11.

Taiwan: PHILIPS TAIWAN LTD., 3rd Fl., San Min Building, 57-1, Chung Shan N. Rd, Section 2, P.O. Box 22978, TAIPEI, Tel. 5513101-5.

Thailand: PHILIPS ELECTRICAL CO. OF THAILAND LTD., 283 Silom Road, P.O. Box 961, BANGKOK, Tel. 233-6330-9.

Turkey: TÜRK PHILIPS TICARET A.S., EMET Department, Inonu Cad. No. 78-80, ISTANBUL, Tel. 43 59 10.

United Kingdom: MULLARD LTD., Mullard House, Torrington Place, LONDON WC1E 7HD, Tel. 01-580 6633.

United States: (Active devices & Materials) AMPEREX SALES CORP., Providence Pike, SLATERSVILLE, R.I. 02876, Tel. (401) 762-9000.
(Passive devices) MEPCO/ELECTRA INC., Columbia Rd., MORRISTOWN, N.J. 07960, Tel. (201) 539-2000.
(IC Products) SIGNETICS CORPORATION, 811 East Arques Avenue, SUNNYVALE, California 94086, Tel. (408) 739-7700.

Uruguay: LUZIELECTRON S.A., Rondeau 1567, piso 5, MONTEVIDEO, Tel. 9 43 21.

Venezuela: IND. VENEZOLANAS PHILIPS S.A., Elcoma Dept., A. Ppal de los Ruices, Edif. Centro Colgate, CARACAS, Tel. 36 05 11.